

CD RECEIVER

KDC-MP425/MP6026 /W6027/W6027Y

KENWOOD

SERVICE MANUAL

© 2003-12 PRINTED IN JAPAN
B53-0116-00 (N) 2704

CD MECHANISM EXTENSION CORD (24P) : W05-0934-00

KDC-MP425

Panel assy
(A64-3187-12)

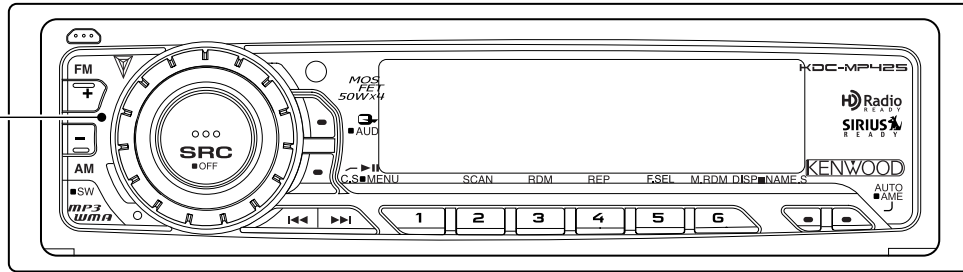

KDC-MP6026

Panel assy
(A64-3194-12)

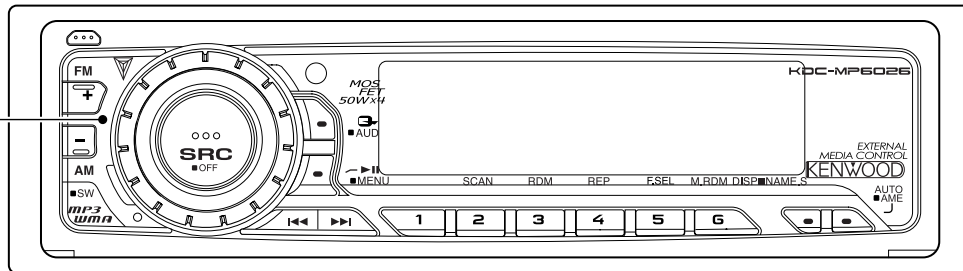

KDC-W6027
/W6027Y

Panel assy
(A64-3197-12)

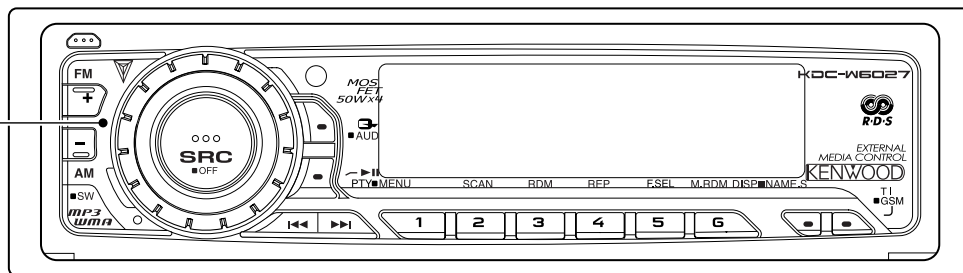

Plastic cabinet assy
(A02-1486-13)

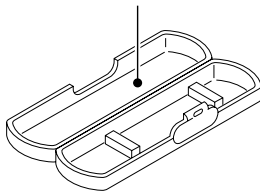

Mounting hardware assy
(J22-0011-03)

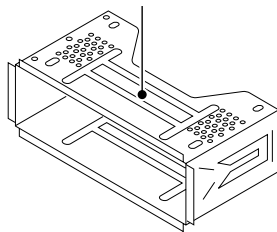

Lever
(D10-4589-04) x2

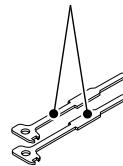

DC cord
(E30-6295-05) *

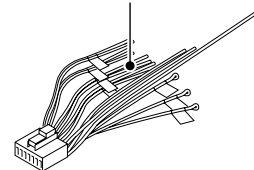

DC cord
(E30-4958-05) *

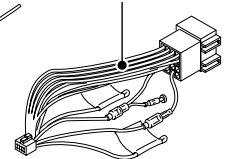

Escutcheon
(B07-3098-02):KDC-MP425
(B07-3083-02):Others

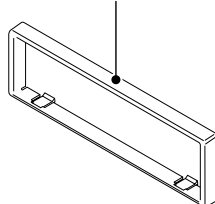

Screw set *
(N99-1719-05)

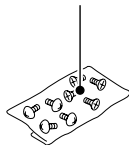

Screw set
(N99-1730-15)

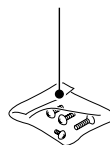

Remote controller assy (RC-505)
(A70-2040-05) *

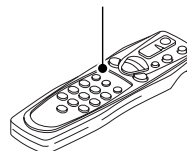

Size AA battery
(Not supplied)



Antenna adaptor
(T90-0523-05) *

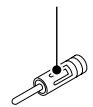

TDF PANEL INFORMATION

MODEL	TDF PANEL No.	TDF NAME
KDC-MP425	Y33-1920-61	TDF-44D
KDC-MP6026	Y33-1920-64	TDF-MP6026
KDC-W6027/W6027Y	Y33-1920-65	TDF-W6027

* Depends on the model. Refer to the parts list.



BLOCK DIAGRAM

MODE	K,M-TYPE	E-TYPE
CD,MP3	3600mV	3600mV
FM	1800mV	1372mV
AM	600mV	855mV
CH	3600mV	3600mV

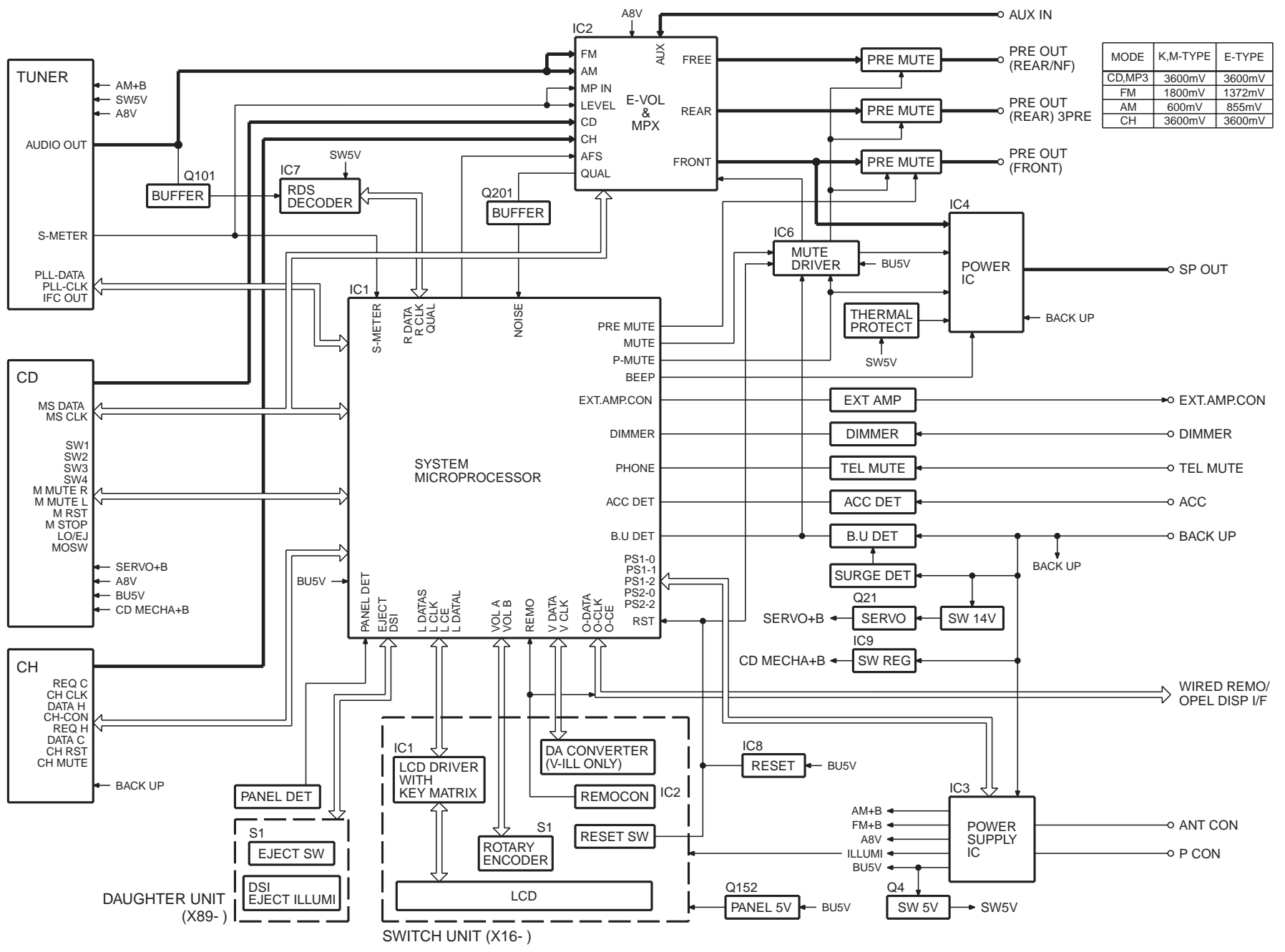

DISASSEMBLY FOR REPAIR

How to Disassemble (PANEL ASSY)

- 1) Remove four screws (A).
- 2) While holding the section (B) indicated with arrows, pull and remove PANEL ASSY.

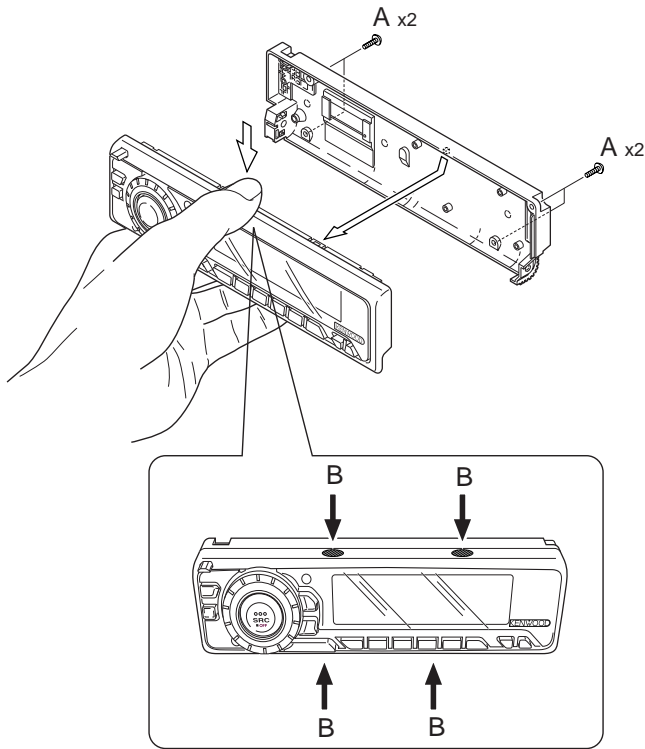

How to install knob (SRC)

- 1) Place knob (F) and knob (G) in the positions indicated in the diagram below.
- 2) While keeping these positions, use a piece of adhesive tape (H) to hold knobs in position, as shown in the diagram.
- 3) Set the rotary (J) position as shown in the diagram.
- 4) While keeping the letters "SRC" horizontally in position, set it to the rotary on the panel.
- 5) Remove the adhesive tape (H).

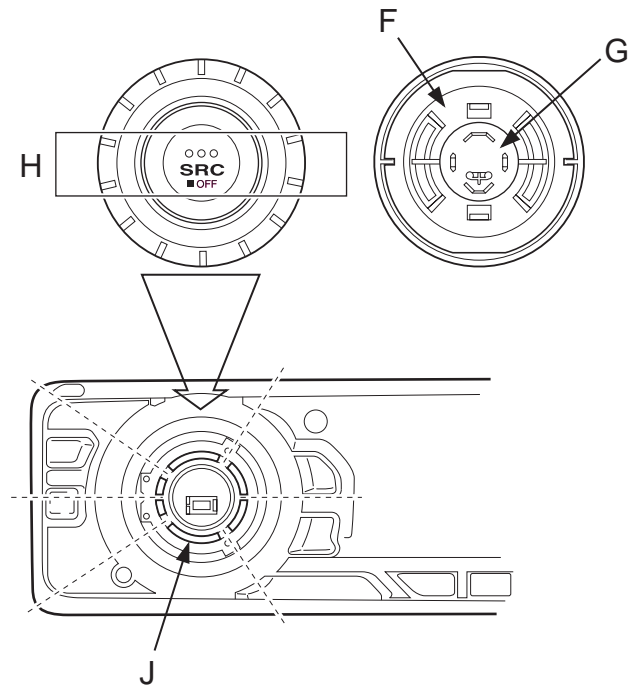

- 3) Pull SWITCH UNIT (C) as indicated in the diagram and remove knob (D).

(The knob (D) is attached to the rotary with hook (E) and it is not possible to remove hook (D) only.)

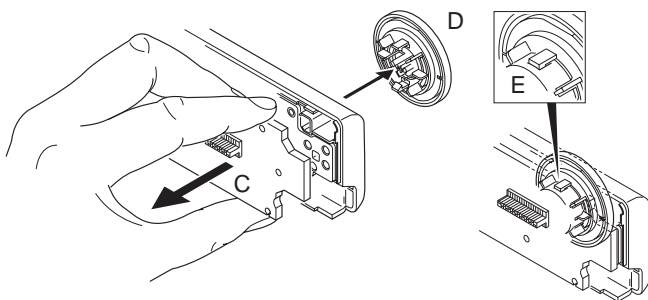

COMPONENTS DESCRIPTION

● SWITCH UNIT (X16-2490-10)

Ref. No.	Application / Function	Operation / Condition / Compatibility
IC1	LCD Driver	Drives LCD
IC2	Remote Control IC	Controls the unit
Q2	REMO ON SW	The power supply of IC2 is turned on when base level goes "L"
Q3	Key Illumination SW (Green)	Lights Green key-illumination when base level goes "H"
Q4	Key Illumination SW (Red)	Lights Red key-illumination when base level goes "H"
Q5	Dimmer Control	Lights LCD Back Light when base level goes "H"

● ELECTRIC UNIT (X34-308x-xx)

Ref. No.	Application / Function	Operation / Condition / Compatibility														
IC1	System μ -COM	Controls FM/AM tuner, the changer, CD mechanism, Panel, volume and tone.														
IC2	E.Vol & N.C.MPX	Controls the source, volume, tone and FM multiplex detector.														
IC3	Power Supply IC	<p>Bu5V (5V), Audio8V (8V), FM+B (8V), AM+B (8V), P-CON, ANT-CON</p> <table border="1" style="margin-left: auto; margin-right: auto;"> <tbody> <tr> <td>SW1</td> <td>OUT</td> </tr> <tr> <td>1.5~3.0</td> <td>Audio ON</td> </tr> <tr> <td>3.5~5.0</td> <td>Audio P-CON ON</td> </tr> <tr> <td>7.0~</td> <td>Audio P-CON, P-ANT ON</td> </tr> <tr> <td>SW2</td> <td>OUT</td> </tr> <tr> <td>2.0~3.0</td> <td>ILL FM ON</td> </tr> <tr> <td>4.0~</td> <td>ILL AM ON</td> </tr> </tbody> </table>	SW1	OUT	1.5~3.0	Audio ON	3.5~5.0	Audio P-CON ON	7.0~	Audio P-CON, P-ANT ON	SW2	OUT	2.0~3.0	ILL FM ON	4.0~	ILL AM ON
SW1	OUT															
1.5~3.0	Audio ON															
3.5~5.0	Audio P-CON ON															
7.0~	Audio P-CON, P-ANT ON															
SW2	OUT															
2.0~3.0	ILL FM ON															
4.0~	ILL AM ON															
IC4	Power IC	Amplifies the front L/R and the rear L/R to 50W maximum.														
IC6	Muting logic IC	Controls logic for muting.														
IC7	RDS decoder															
IC8	Reset IC	"L" when detection voltage goes below 3.6V or less.														
IC9	SW Regulator	Power Supply for MP3														
Q1	Serge Detection	"L" when the back-up voltage becomes more than 24V (momentary power down). "H" when the back-up voltage becomes less than 24V.														
Q2	BACK-UP Detection	"L" when B.u is present. "H" when B.u is absent or momentary power down is detected.														
Q3	ACC Detection	"L" when Acc is present.														
Q4	SW 5V	ON when the base is "L".														
Q21	Servo Regulator															
Q22	Servo SW															
Q23	Control Power Supply IC															
Q31	Dimmer Control	Dimmer ON when the base is "H".														
Q41	SW Regulator Control															
Q101	Composite signal buffer															

COMPONENTS DESCRIPTION

Ref. No.	Application / Function	Operation / Condition / Compatibility
Q151	DSI Driver	DSI lights when the base is "L". DSI turns off when the base is "H". DSI turns on and off when panel is taken off.
Q152	Panel 5V SW	When the panel is attached, the base goes "L", turning the Tr ON to supply 5V to the panel. When panel is taken off, panel 5V cut off.
Q153,154	ILL Control	ILL lights when the base of Q153 is "H".
Q201	Noise buffer	
Q350	Pre and NF Mute SW (not always Pre and NF)	Drives the Pre and NF Mute sw (Q351,355) when the base is "L".
Q351	Pre / NF Mute SW	Mutes the Pre Rear Lch or NF Lch when the base is "H".
Q352	Pre / NF Mute SW	Mutes the Pre Rear Rch or NF Rch when the base is "H".
Q354	Pre and NF Mute SW (not always Pre and NF)	Drives the Pre and NF Mute sw (Q352,356) when the base is "L".
Q355	Pre Mute SW	Mutes the Front Lch when the base is "H".
Q356	Pre Mute SW	Mutes the Front Rch when the base is "H".

MICROCOMPUTER'S TERMINAL DESCRIPTION

● SYSTEM MICROCOMPUTER : UPD703030GC044 (X34 : IC1)

Pin No.	Pin Name	I/O	Application	Truth value table	Processing Operation Description
1	PLL CLK	I/O	CLK output terminal to F/E		
2	Not used	O			
3	PANEL-DET	I	Panel DET terminal		No panel DET : L, Panel DET : H
4	IC2 SDA	I/O	DATA input/output terminal with E-VOL		
5	IC2 SCL	I/O	CLK output terminal to E-VOL		
6	VDD	-			
7	VSS	-			
8	FLIP-DET	I	Flip DET terminal		L : Panel DET, H : Panel flippable
9	BEEP	O	BEEP output terminal		
10	REMO	I	Remote control input		
11	R QUAL	I	RDS decoder QUAL input terminal		
	Not used	O	Destination other than E and E2		

MICROCOMPUTER'S TERMINAL DESCRIPTION

Pin No.	Pin Name	I/O	Application	Truth value table	Processing Operation Description
12	R DATA	I	RDS decoder DATA input terminal		
	Not used	O	Destination other than E and E2		
13	L CE	O	CE output terminal for LCD driver		
14	Not used	O	Non variable illumination switch destination		
15	Not used	O	Non variable illumination switch destination		
16	DSI	I/O	EJECT KEY ILL, GUIDE ILL, DSI control terminal		FLIP-DET "H" and PANEL-DET is "L" : "H" / "L" FLIP-DET "H" and PANEL-DET is "H" : "L"
17	DIM CON	O	Dimmer control terminal		50ms interval : "H" / "L"
18	TEST	-			
19	ILL CON	O	During FLIP DET ILL+B OFF		During FLIP DET "L" : H
20	VOL A	I	Volume key input		When looking at VOL, also look at FLIPDET
21	VOL B	I	Volume key input		When looking at VOL, also look at FLIPDET
22	MOSW	O	CD mechanism MOTOR IC SW		Loading, Eject, Brake : H
23	LO/EJ	I/O	CD mechanism LOADING, EJECT switching		STOP, Brake : Hi-Z, Loading : L, Eject : H
24	M STOP	O	STOP request to CD mechanism		
25	M RST	O	Reset output terminal to CD mechanism		Normal : H, Reset : L
26	MUTE	I/O	MUTE terminal		Hi-Z : Mute ON, L : Mute OFF
27	LOE/LIM SW	I	CD DOWN SW DET terminal		H : Chucking
28	M-MUTE L	I	MUTE request terminal from CD mechanism		L : Mute request
29	M-MUTE R	I	MUTE request terminal from CD mechanism		L : Mute request
30	PANEL 5V	I/O	Panel 5V control terminal		Panel DET : L, Detached, Momentary power down : H
31	RESET	I			Normal : H, Reset : L
32	XT1	I			32kHz
33	XT2	I			32kHz
34	REGC	-			Connect 1 μ F condenser to GND
35	X2	I			20MHz
36	X1	I			20MHz
37	VSS	-			
38	VDD	-			
39	CLKOUT	-			
40	IC2 TYPE1	I	E-VOL setting switching terminal		
41	IC2 TYPE0	I	E-VOL setting switching terminal		
42~44	TYPE2-TYPE0	I	Destination switching terminal	③	
45	CD MECHA+B	I/O	Power supply control terminal for MP3		ON : L, OFF : Hi-Z
46	SW5V	I/O	Control terminal for SW5V		ON : L, OFF : Hi-Z
47,48	PS2-0, PS2-1	O	Control terminal for power supply IC	②	
49~51	PS1-0~PS1-2	O	Control terminal for power supply IC	①	
52	B.U-DET	I	Momentary power down DET terminal		BU DET : L, BU no DET (momentary power down) : H
53	ACC-DET	I	ACC DET terminal		ACC DET : L, ACC no DET : H

MICROCOMPUTER'S TERMINAL DESCRIPTION

Pin No.	Pin Name	I/O	Application	Truth value table	Processing Operation Description
54	DIMMER	I	Small DET terminal		ON : L, OFF : H
55	BVDD	-			
56	BVSS	-			
57	Not used	O	Non Ext AMP CON destination		Output "L"
58	(SVR)	O	POWER IC SVR control terminal		Momentary power down : H
59	P-MUTE	O	POWER IC MUTE output terminal		During POWER OFF : L, During ALL OFF : L, When TEL MUTE : L
60	P-STBY	O	POWER IC STBY output terminal		When POWER IC ON : H, OFF : L
61	Not used	O			
62	PRE MUTE R	O	Rch PRE MUTE output		When momentary power down : L, M-MUTE R : L (during CD), 2 zone : H fixed
63	PRE MUTE L	O	Lch PRE MUTE output		When momentary power down : L, M-MUTE L : L (during CD), 2 zone : H fixed
64	AFS	O	Constant switching terminal at noise DET		During FM seek and AF search : L, During reception : H
65	O-DATA	I/O	External display DATA terminal		
	Not used	O	Non external display destination		No OPEL DISP : L
66	O-CLK	I/O	External display CLK terminal		
	Not used	O	Non external display destination		No OPEL DISP : L
67	O-CE	I/O	External display CE terminal		
	Not used	O	Non external display destination		No OPEL DISP : L
68	LX_RST	O	Reset output to external devices		Normally : L, System RST return, then after 400msec or more : H then L
69	LX_CON	O	Control output to external devices		ON : H, OFF : L
70	AVCONT	O	AD reference voltage control output		While in operation : H
71	AVDD	-			
72	AVSS	-			
73	AVREF	-	AD reference voltage control input		Connect to 70 pin
74	PHONE	I	PHONE DET terminal		TEL MUTE : 1V or lower, NAVI MUTE : 2.5V or higher
75	TYPE3	I	Destination switching terminal		
76~81	Not used	I			
82	S-METER	I	S-meter DET terminal		
83	NOISE	I	FM noise DET terminal		
84	IFC-OUT	I	F/E IFC OUT input terminal		
85	LX_MUTE	I	MUTE request from external devices		H : MUTE ON, L : MUTE OFF
86	LX_REQ_M	O	Request output to external devices		Request DET : L
87	R-CLK	I	RDS decoder CLK input terminal		
	Not used	O	Non RDS destination		Output L fixed
88	LX_REQ_S	I	Request input from external devices		Request DET : L
89	KEY-REQ	I	Communication request from LCD driver		L : KEY input

MICROCOMPUTER'S TERMINAL DESCRIPTION

Pin No.	Pin Name	I/O	Application	Truth value table	Processing Operation Description
90	LO.S SW	I	Loading start SW DET terminal		Loading start : L
91	12EJE SW	I	12cm DISC EJECT position DET SW terminal 12 or 8cm DET		12cm DISC : L
92	EJECT	I	EJECT DET terminal		L : KEY input
93	Not used	O			Output L fixed
94	LX_DATA_S	I	DATA input terminal from external devices		
95	LX_DATA_M	O	DATA output terminal for external devices		Last retention
96	LX_CLK	I/O	CLK input/output terminal with external devices		
97	L DATAL	I	Data input from LCD driver		
98	L DATAS	O	DATA output terminal to LCD driver		
99	L CLK	O	CLK output terminal to LCD driver		
100	PLL DATA	I/O	DATA input/output terminal with F/E		

Truth value table

①

PS1-0	PS1-1	PS1-2	AUDIO	P-CON	P-ANT
L	L	L	OFF	OFF	OFF
H (L)	L (H)	L	ON	OFF	OFF
H	H	L	ON	ON	OFF
H	H	H	ON	ON	ON

②

PS2-0	PS2-1	ILLUMI	FM+B	AM+B
L	L	OFF	OFF	OFF
H (L)	L (H)	ON	ON	OFF
H	H	ON	OFF	ON

③

MODEL	DESTINATION	TYPE		
		0	1	2
KDC-X579	K	L	L	L
KDC-MP425	K	H	L	L
KDC-MPV525	K	L	H	L
KDC-MPV5025	K	L	L	L
KDC-WV6027	E	H	L	H
KDC-W6027	E	L	L	H
KDC-W6027Y	E	L	L	H
KDC-MPV7026	M	H	H	L
KDC-MP6026	M	L	H	H

TEST MODE

1. How to enter the test mode

- While holding the Preset 1 and Preset 3 keys, reset the unit.

2. How to exit from the test mode

- Reset the unit, momentary power down, ACC OFF, power OFF, and Panel detached.
- (Note) The test mode cannot terminated by Panel is fall down.

3. Initial status in the test mode

- Sources : All OFF.
- Display : All segments are lit.
- Volume : -10 dB (displayed as 30)
- Loudness : OFF
- CRSC : OFF regardless of the presence of switching function.
- SYSTEM Q : Flat.
- BEEP : When pressing any keys, the buzzer generates a beep at any time.
- DISPLAY TYPE : TYPE A

4. RDS automatic measurement

- An addition to disposal of substitute for visual check PS display as usual production lines.
- P-CON terminal is OFF by force, when received the PS data and in case of corroboration PS display is "RDS_TEST". ("_" is mean blank.)
- This disposal is test mode only.
- P-CON is switching the source or return with power on→off.

5. Special display in Tuner mode

When any of the following messages is displayed in Tuner mode, the front end may be abnormal.

- "TNE 2P NG": The EEPROM is set to the default (unstable values) because the F/E was shipped without passing through the adjustment process, etc.
- "TNCON NG": Communication with the F/E is not possible.

6. Forced switching of K3I

- Each press of the Preset 6 key in Tuner mode should switch K3I from AUTO → Forced Wide → Forced Middle → Forced Narrow → AUTO. The initial status is AUTO and the display shows these modes as follows.
- AUTO : FMA
- Forced Wide : FMW
- Forced Middle : FMM
- Forced Narrow : FMN

7. CD Receiver Test Mode Specification

- When resetting to start, forced ejection of CD is prohibited. When a CD is in place, the CD is not recognized when reset.
- ►► When this key is pressed, the mechanism jumps to the following track.
No9 → No15 → No10 → No11 → No12 → No13 → No22 → No14 → No9 (Return to the first track.)
- ◄◄ When this key is pressed, the track goes down by one from the currently played track.
- When a CD being played, by pressing [1] key intermittently, the mechanism can be made to jump to Track No. 28.

8. Audio-related specifications

- A short press of the Q key initiates the audio adjustment mode.
- Pressing the * key on the remote initiates the audio adjustment mode.
- Fader is selected to the initial item.
- Continuous holding of a remote control key is inhibited.
- Bass, Middle and Treble are adjusted in 3 steps of -8/0/+8 with the Track Up/Down keys.
- Balance is adjusted in 3 steps of L15/0/R15 with the Track Up/Down keys.
- Fader is adjusted in 3 steps of F15/0/R15 with the Track Up/Down keys.
- Volume Offset is adjusted in 2 steps of -8/0 with the Track Up/Down keys.

9. Menu-related specifications

- A short press of the MENU key initiates the Menu mode. Except, tape source is usually press and hold 1 second to enter the menu mode and short press initiates turn over.
- Pressing the DNPP/SBF key on the remote initiates the Menu mode.
- Continuous holding of a remote control key is inhibited.
- Contrast is adjusted in 3 steps of 0/5/10 (5x7dot), 0/4/7 (14seg) with the Track Up/Down keys.

10. Backup current measurement

- When the unit is reset while ACC is OFF (i.e. by turning Back-Up ON), the MUTE terminal goes OFF in 2 seconds in place of 15 second.

TEST MODE

11. Special display when the display is All ON

Pressing the Preset keys while the power is All OFF displays the following information.

[14seg 8 digits]

1key	Version display (8 digits, Month/Day/Hour/Minute) (Display) xxxxxxxx
2key	
3key	Short press: View power ON time. (The All OFF period is not counted.) Long press/hold: Clear power ON time. (Display) PONxxxxx Max. 65535 (hours)
4key	Short press: Display TAPE operation time. Long press/hold: Clear TAPE operation time. (Display) TPTxxxxx Max. 65535 (hours)
5key	Short press: Display TAPE ejection count. Long press/hold: Clear TAPE ejection count. (Display) EJCxxxxx Max. 65535 (times)
6key	Short press: Display Panel open/close count. Long press/hold: Clear Panel open/close count. (Display) PCxxxxx Max. 655359 (times)
FM key	Display ROM collection version (Display) ROM Rxxx Invalid :ROM R-

[15x7dot 12 digits]

1key	Version display (8 digits, Month/Day/Hour/Minute) (Display) SYS_xxxxxxxx
2key	
3key	Short press: View power ON time. (The All OFF period is not counted.) Long press/hold: Clear power ON time. (Display) PonTim_xxxxx Max. 65535 (hours)
4key	Short press: Display TAPE operation time. Long press/hold: Clear TAPE operation time. (Display) TPTim_xxxxx Max. 65535 (hours)
5key	Short press: Display TAPE ejection count. Long press/hold: Clear TAPE ejection count. (Display) EjeCnt_xxxxx Max. 65535(times)
6key	Short press: Display Panel open/close count. Long press/hold: Clear Panel open/close count. (Display) PnCnt_xxxxx Max. 655359 (times)
FM key	Display ROM collection version (Display) ROM Rxxx Invalid: ROM R-

12. Other specifications

- The line mute against times are 1 second from 10 seconds when starting the test mode.

■ Security

• Forced Power ON mode (All models)

Even when the security is approved, resetting the unit while holding the Q and 4 keys makes it possible to turn the power ON for 30 minutes. After 30 minutes have elapsed, it is not possible to return to the previous condition unless the unit is reset again.

• Method of registration of the security code after EEPROM (F/E) replacement (Code security model)

1. Enter the test mode. (See How to enter the test mode)
2. Press the MENU key to enter the MENU.
3. When the message "Security" is displayed, press and hold the Track Up/Down key for 1second to enter the Security registration mode.
4. Enter the code using the FM/AM/Track Down keys.
 - FM key : Number up
 - AM key : Number down
 - Track Up key : Cursor right shift
 - Track Down key : Cursor left shift
5. Hold down the Track Up key for at least 3 seconds and the message, "RE-ENTER" appears, so once again enter the code according to Step 4 above.
6. Press and hold the Track Up key for 3 seconds until "APPROVED" is displayed.
7. Exit from the test mode. (See 2 How to exit from the test mode)
(Note) All Clear is not applicable to the security code of this model.

• Simplified method of clearing the security code

1. While the code entry is requested, press and hold the Track Up key for 3 seconds while holding the AUTO key pressed. (----will disappear.)
2. Enter "KCAR" from the remote.
 - Press the 5 key on the remote twice, then press the Track Up key. (This enters "K")
 - Press the 2 key on the remote 3 times, then press the Track Up key. (This enters "C")
 - Press the 2 key on the remote once, then press the Track Up key. (This enters "A")
 - Press the 7 key on the remote twice, then press the Track Up key. (This enters "R")
3. Security function is canceled and the unit enters the All OFF mode.
4. If you commit a mistake in the code entry, the unit enters the code request mode.

PC BOARD (COMPONENT SIDE VIEW)

ELECTRIC UNIT X34-308x-xx (J74-1447-42)

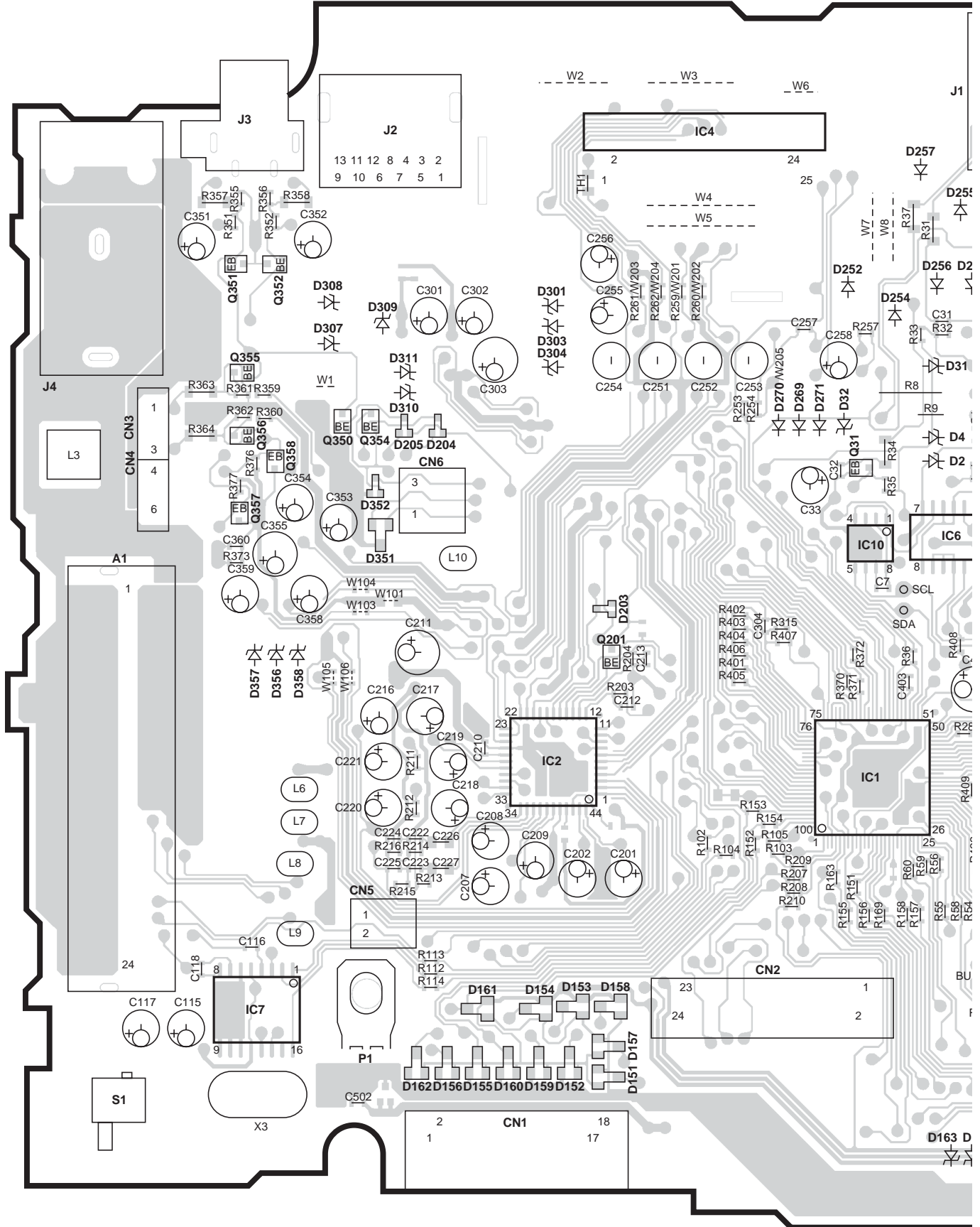

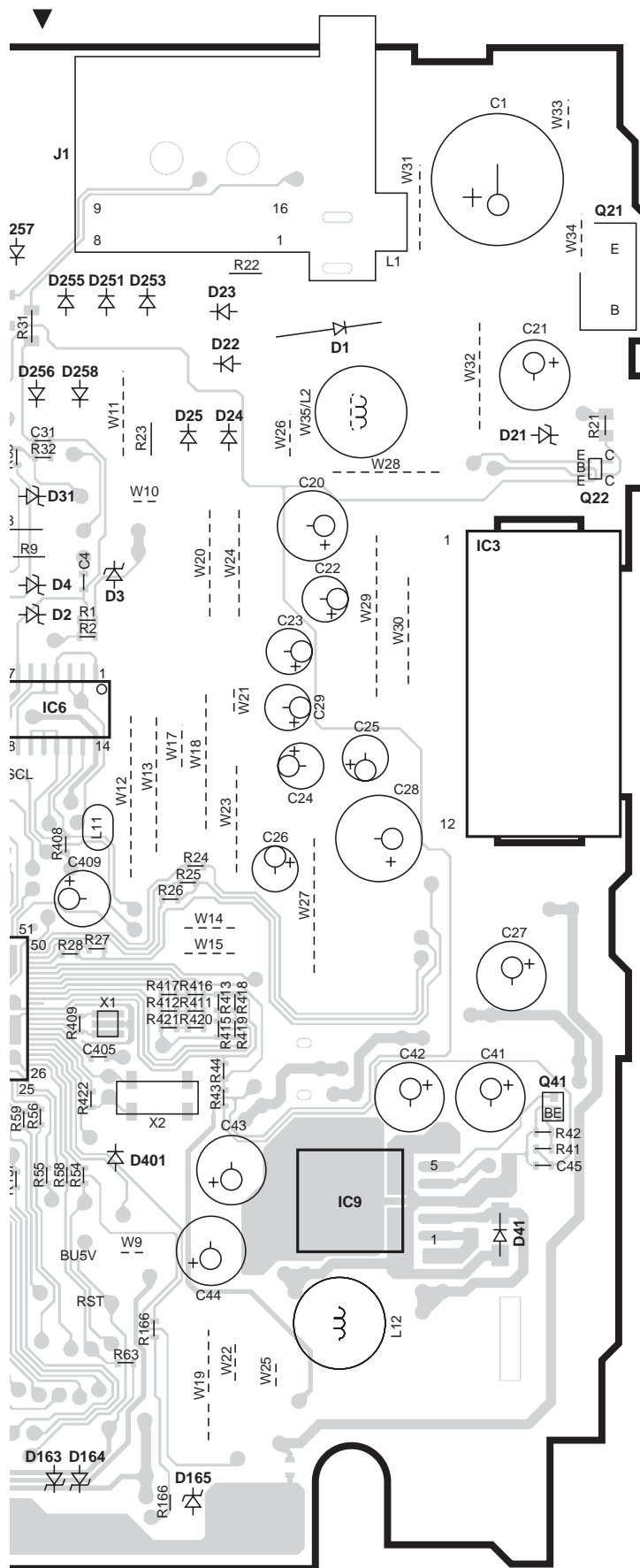

DAUGHTER UNIT X89-2570-10 (J74-1450-02)

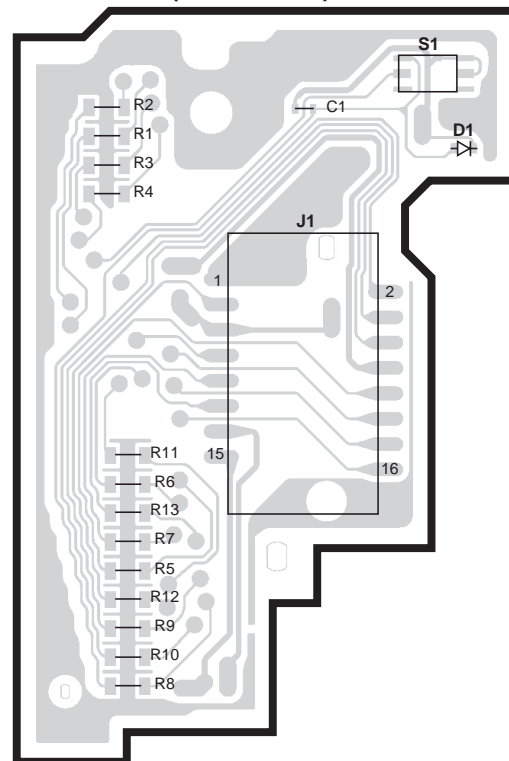

X34-308x-xx

Ref. No.	Address
IC1	5J
IC2	5H
IC3	3L
IC4	2I
IC6	4K
IC7	6G
IC9	6L
Q21	2M
Q22	3M
Q31	3J
Q41	5M
Q201	4I
Q350	3G
Q351	3G
Q352	3G
Q354	3H
Q355	3G
Q356	3G

Refer to the schematic diagram for the values of resistors and capacitors.

PC BOARD (FOIL SIDE VIEW)

ELECTRIC UNIT X34-308x-xx (J74-1447-42)

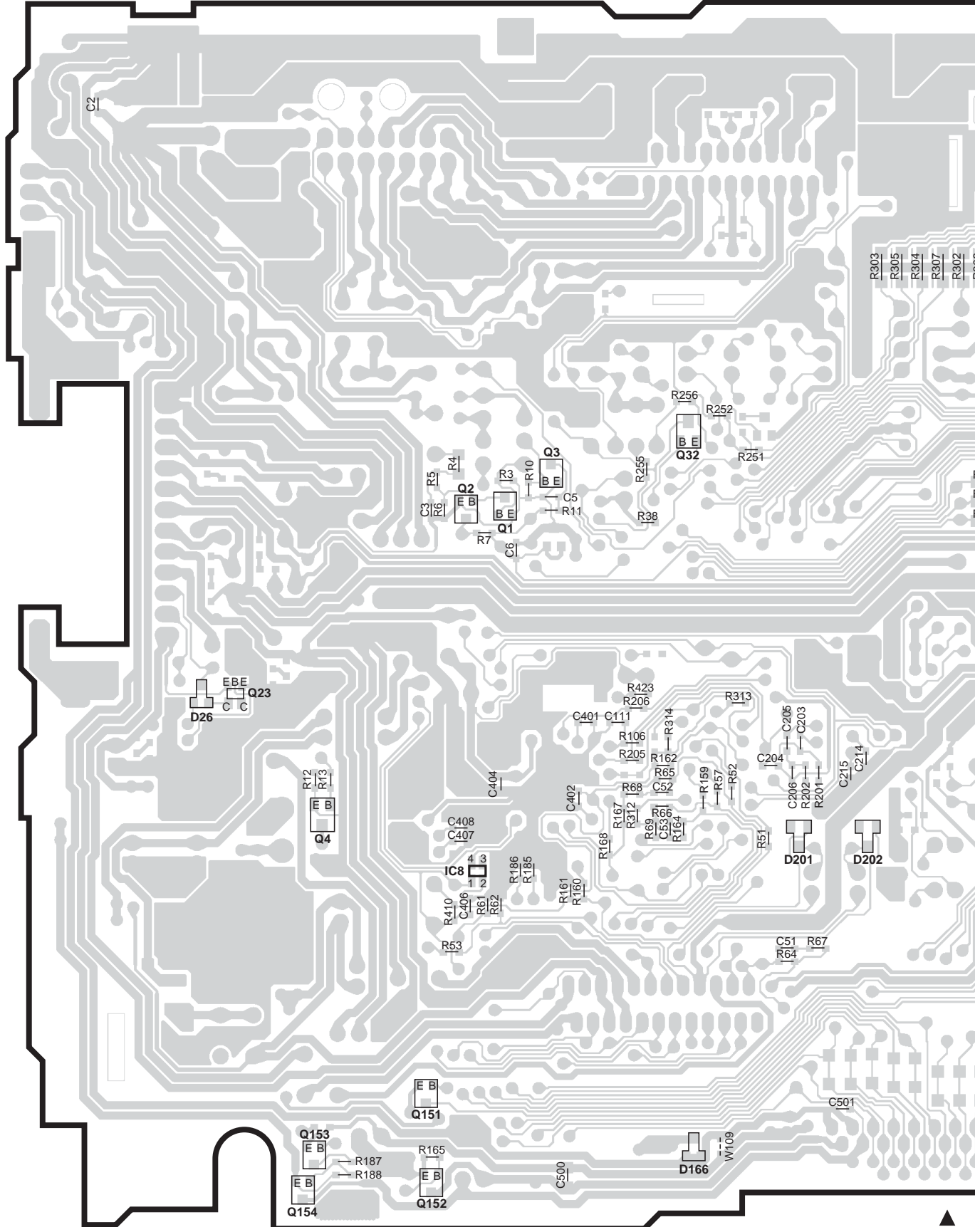

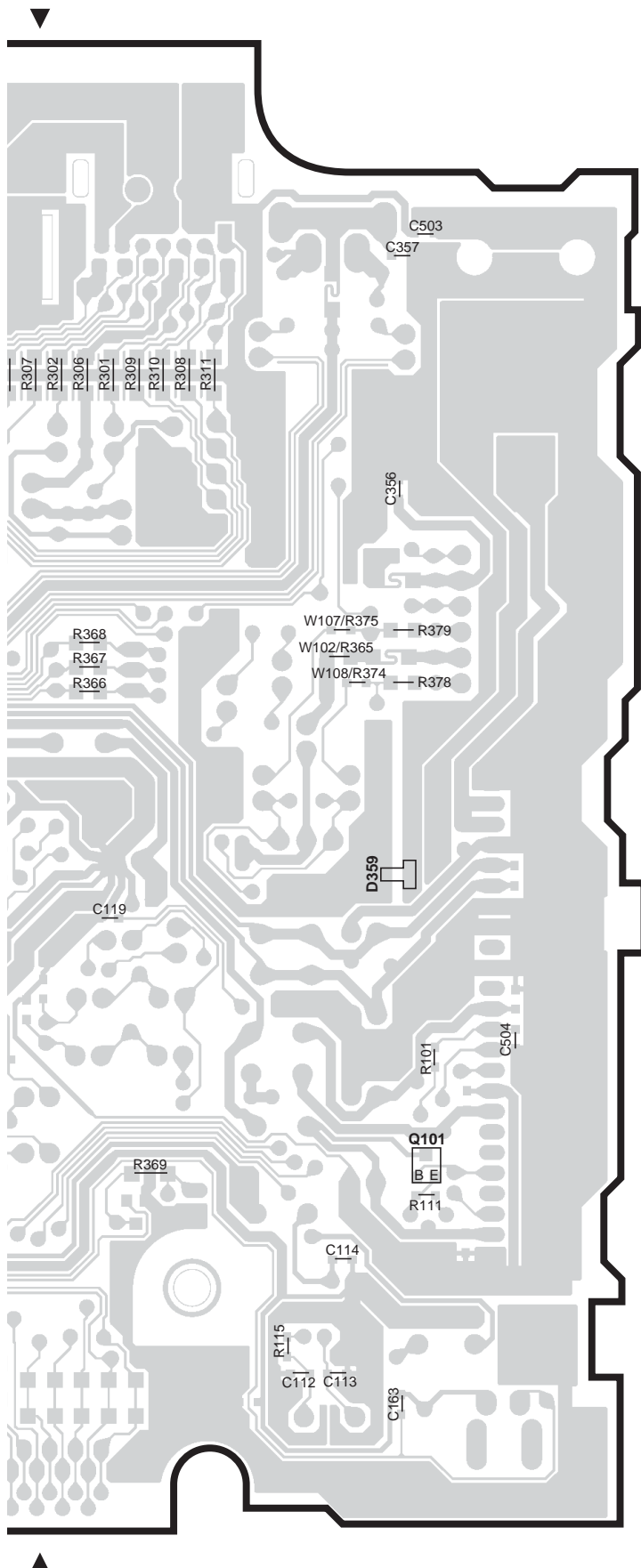
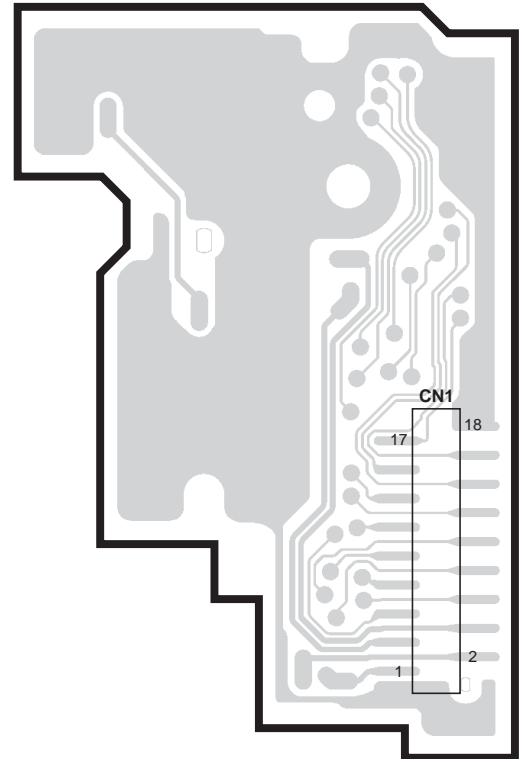
DAUGHTER UNIT
X89-2570-10 (J74-1450-02)

X34-308x-xx

Ref. No.	Address
IC8	5R
Q1	4R
Q2	4R
Q3	3R
Q4	5Q
Q23	5Q
Q101	5V
Q151	7R
Q152	7R
Q153	7Q
Q154	7Q

Refer to the schematic diagram for the values of resistors and capacitors.

KDC-MP425/MP6026
KDC-W6027/W6027Y

PC BOARD (COMPONENT SIDE VIEW)

CD PLAYER UNIT X32-5500-00 (J74-1552-12)

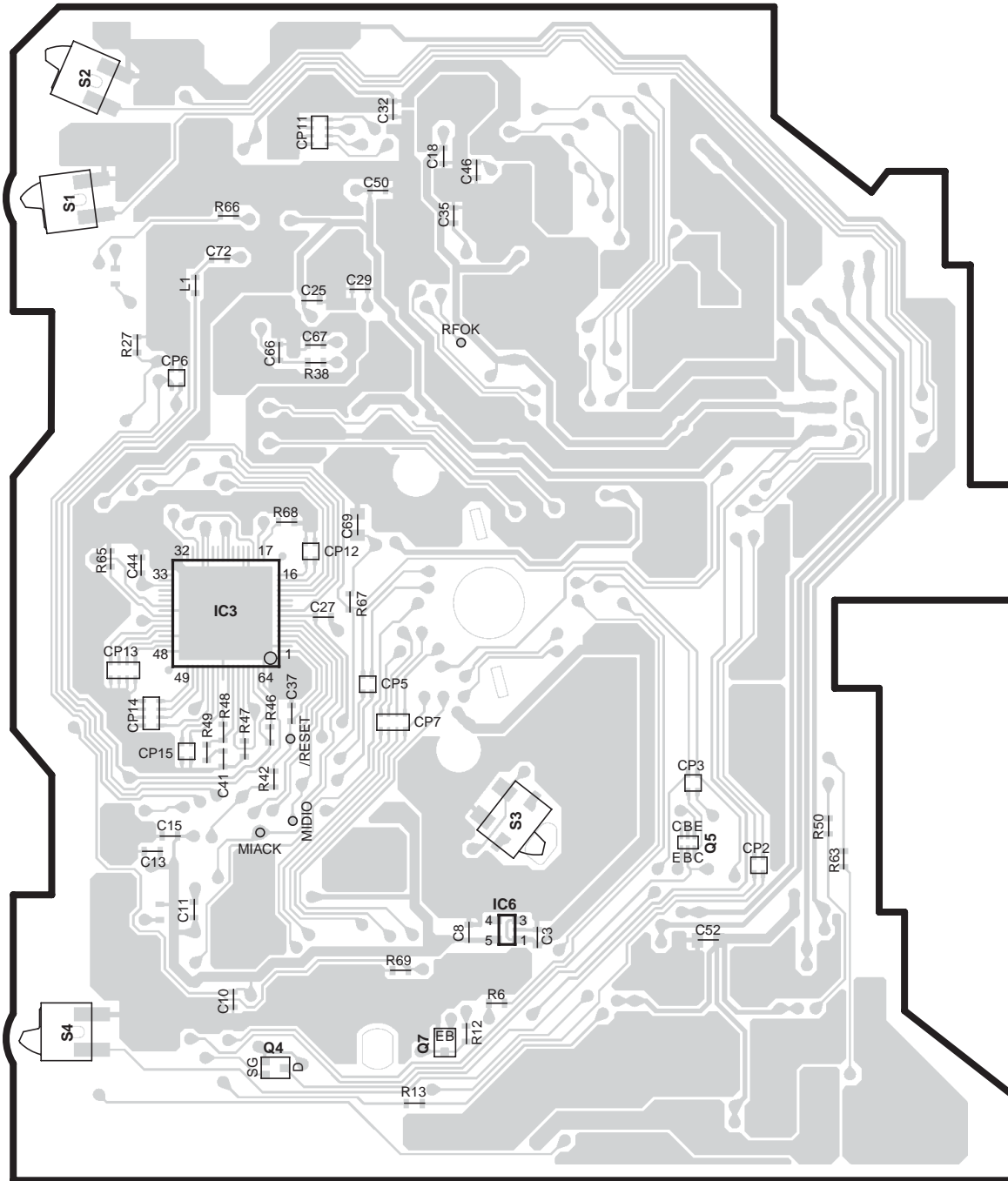

X32-5500-00

Ref. No.	Address
IC3	4AA
IC6	5AB
Q4	5AA
Q5	5AC
Q7	5AB

Refer to the schematic diagram for the values of resistors and capacitors.

PC BOARD (FOIL SIDE VIEW)

CD PLAYER UNIT X32-5500-00 (J74-1552-12)

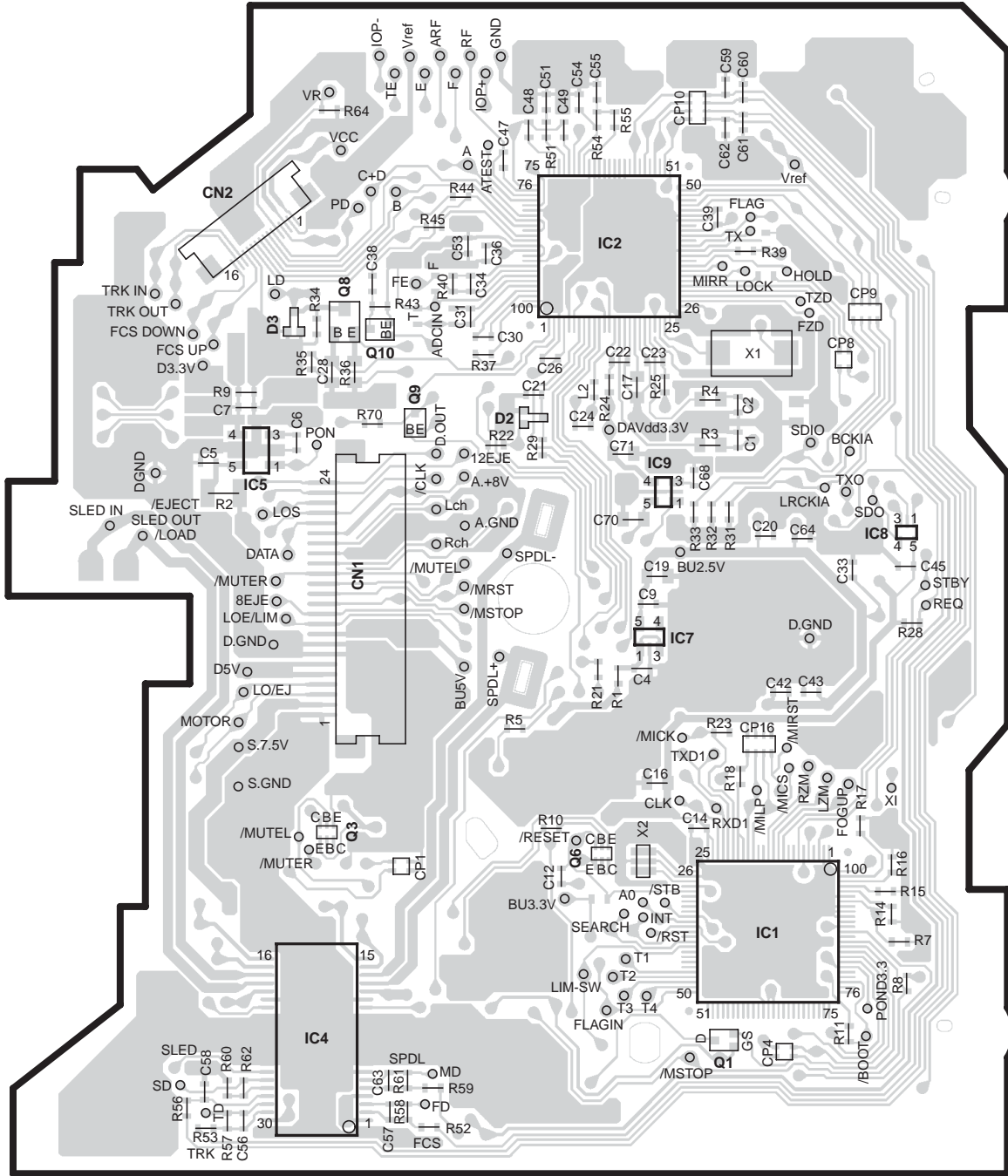

X32-5500-00

Ref. No.	Address	Ref. No.	Address
IC1	5AH	Q1	5AH
IC2	2AG	Q3	5AF
IC4	5AF	Q6	5AG
IC5	3AF	Q8	2AF
IC7	4AG	Q9	3AF
IC8	3AH	Q10	3AF
IC9	3AG		

Refer to the schematic diagram for the values of resistors and capacitors.

KDC-MP425/MP6026
KDC-W6027/W6027Y

ELECTRIC UNIT (X34-308x-xx)

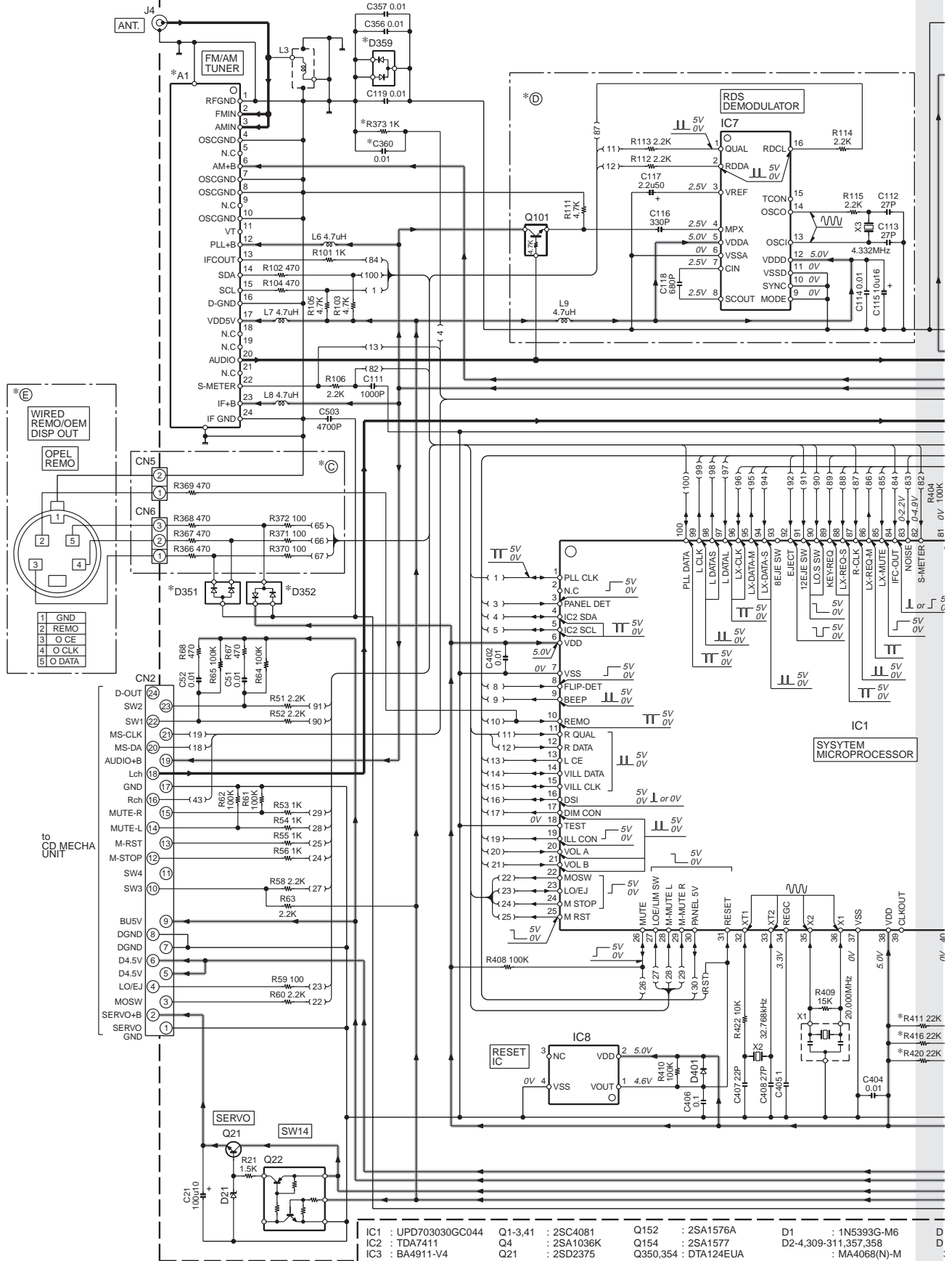

IC1 : UPD70303GC044	Q1-3,41 : 2SC4081	Q152 : 2SA1576A	D1 : 1N5393G-M6
IC2 : TDA7411	Q4 : 2SA1036K	Q154 : 2SA1577	D2-4,309-311,357,358
IC3 : BA4911-V4	Q21 : 2SD2375	Q350,354 : DTA124EUA	MA4068(N)-M
IC4 : TB2903H	Q22,23 : UMC2N		MA4082(N)-L
IC6 : HD74HC27FP-E	Q31,153 : DTC144EUA		AM01ZNF
IC7 : SAA6581T	Q32 : DTA123JK		DAN202U
IC8 : PST3436UL	Q101,201,351,352, 355-358 : DTC143TUA		HZS5B1
IC9 : SI-8050JD	Q151 : DTA114YUA		MA4056-M
			SFPB-54V

KDC-MP425/MP6026
KDC-W6027/W6027Y

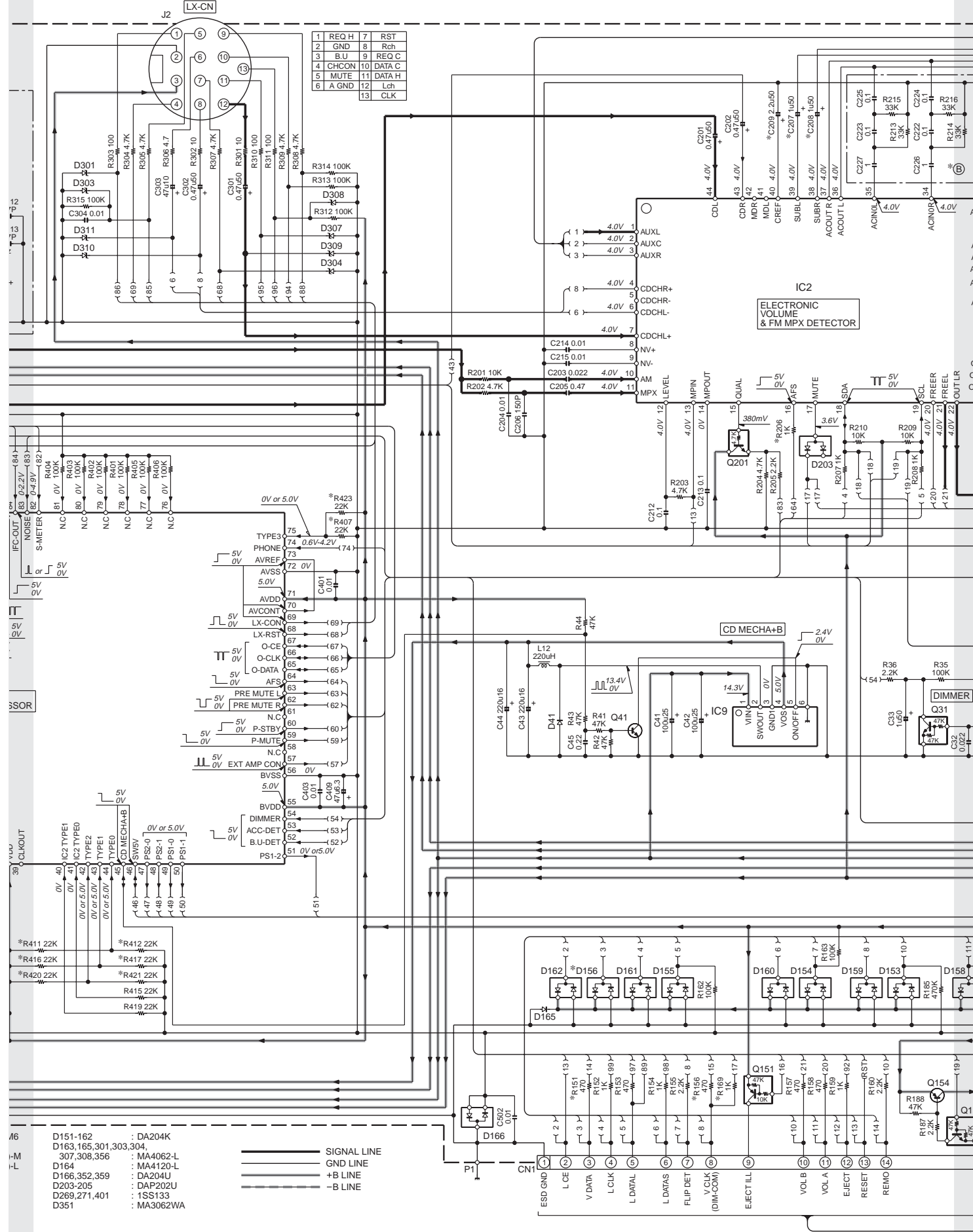

1	REQ H	7	RST
2	GND	8	Rch
3	B.U	9	REQ C
4	CHCON	10	DATA C
5	MUTE	11	DATA H
6	A GND	12	Lch
		13	CLK

IC2
ELECTRONIC VOLUME & FM MPX DETECTOR

CD MECHA+B

DIMMER
Q31

- D151-162 : DA204K
- D163,165,301,303,304, 307,308,356 : MA4062-L
- D164 : MA4120-L
- D166,352,359 : DA204U
- D203-205 : DAP202U
- D269,271,401 : 1S5133
- D351 : MA3062WA

— SIGNAL LINE
— GND LINE
— +B LINE
— -B LINE

KDC-MP425/MP6026
KDC-W6027/W6027Y

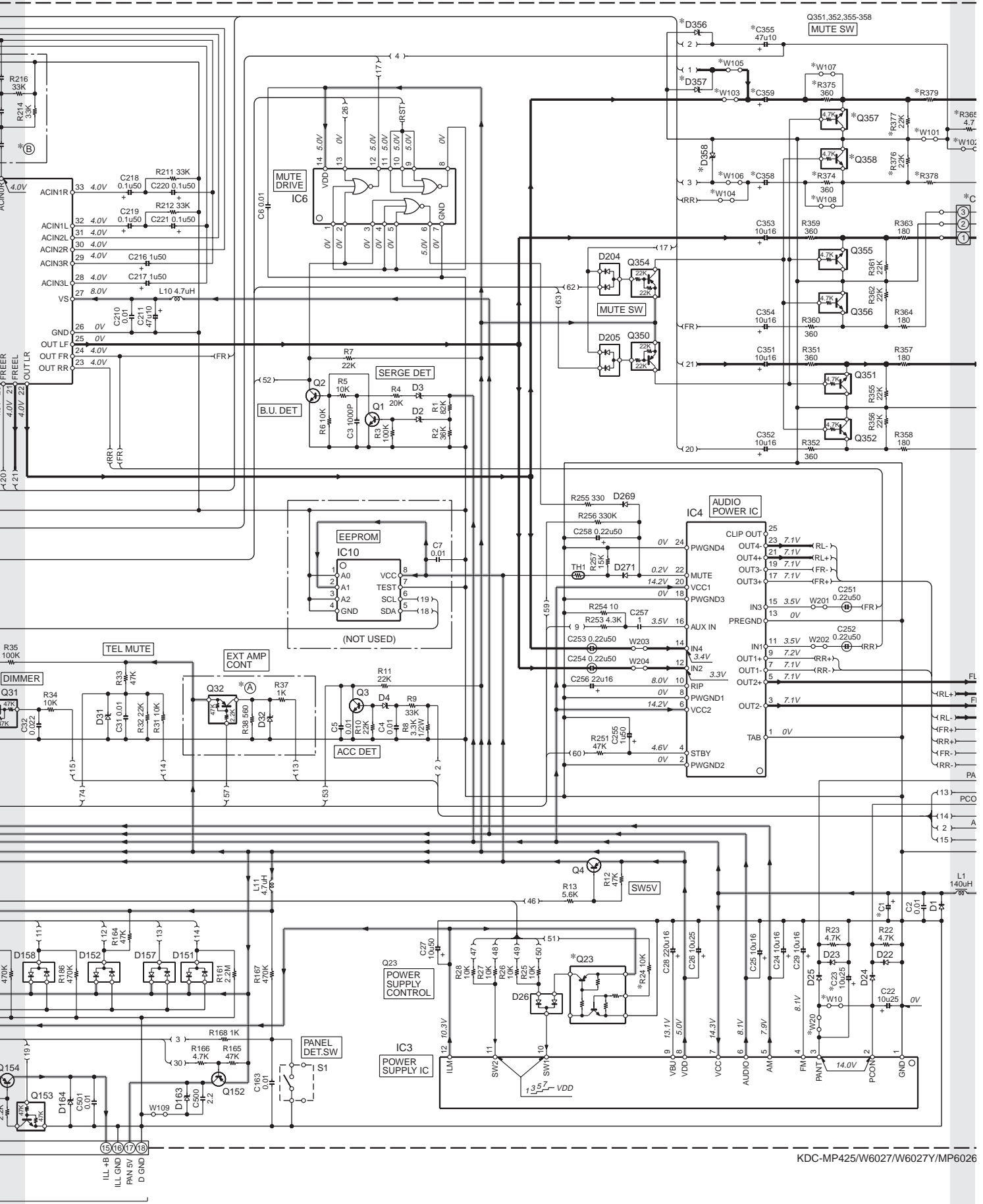

KDC-MP425/W6027/W6027Y/MP6026

SWITCH UNIT (X16-2490-10)

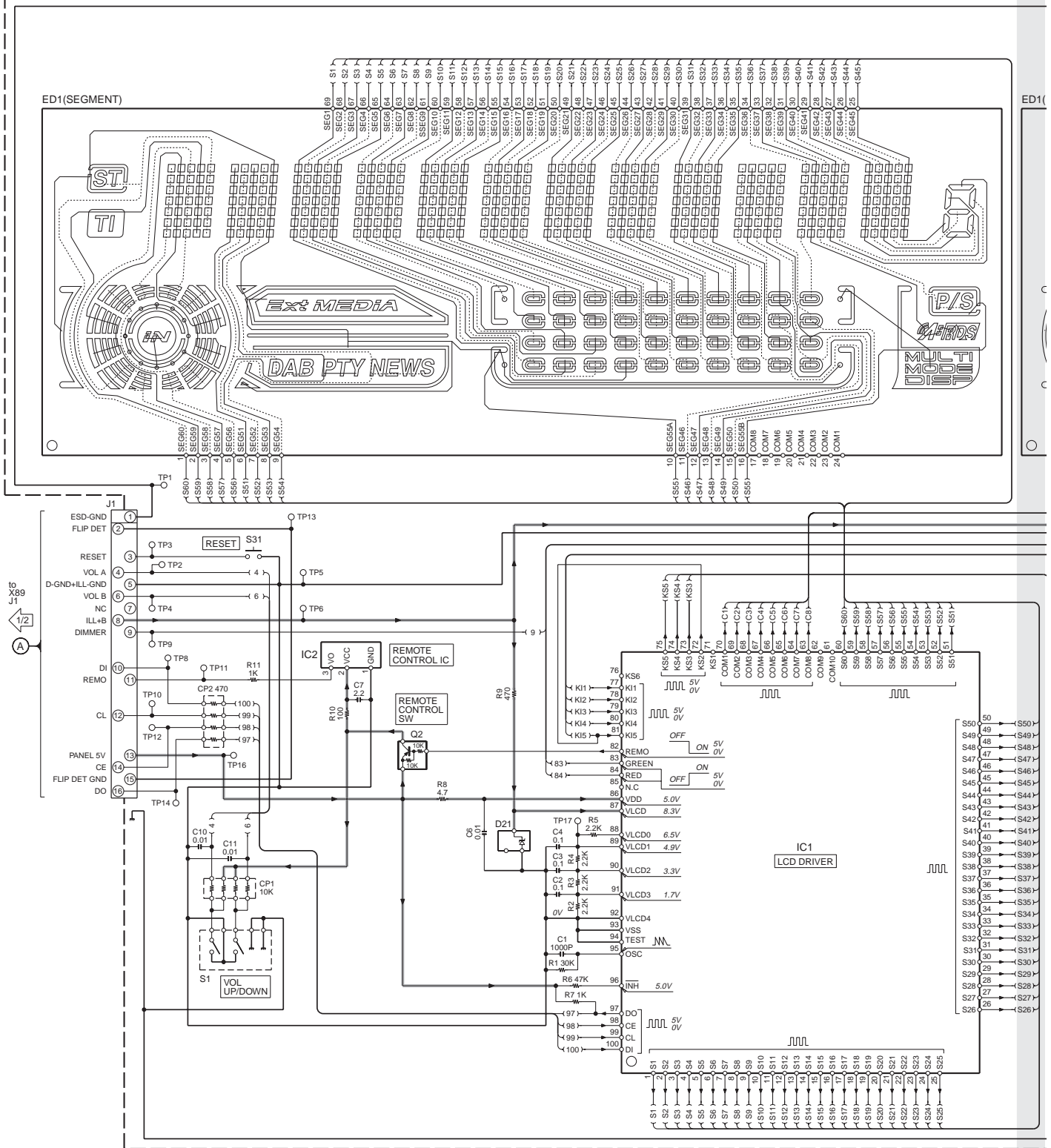

CAUTION : For continued safety, replace safety critical components only with manufacturer's recommended parts (refer to parts list).

⚠ Indicates safety critical components. To reduce the risk of electric shock, leakage-current or resistance measurements shall be carried out (exposed parts are acceptably insulated from the supply circuit) before the appliance is returned to the customer.

- DC voltages are as measured with a high impedance voltmeter. Values may vary slightly due to variations between individual instruments or/and units.

ED1(COMMON)

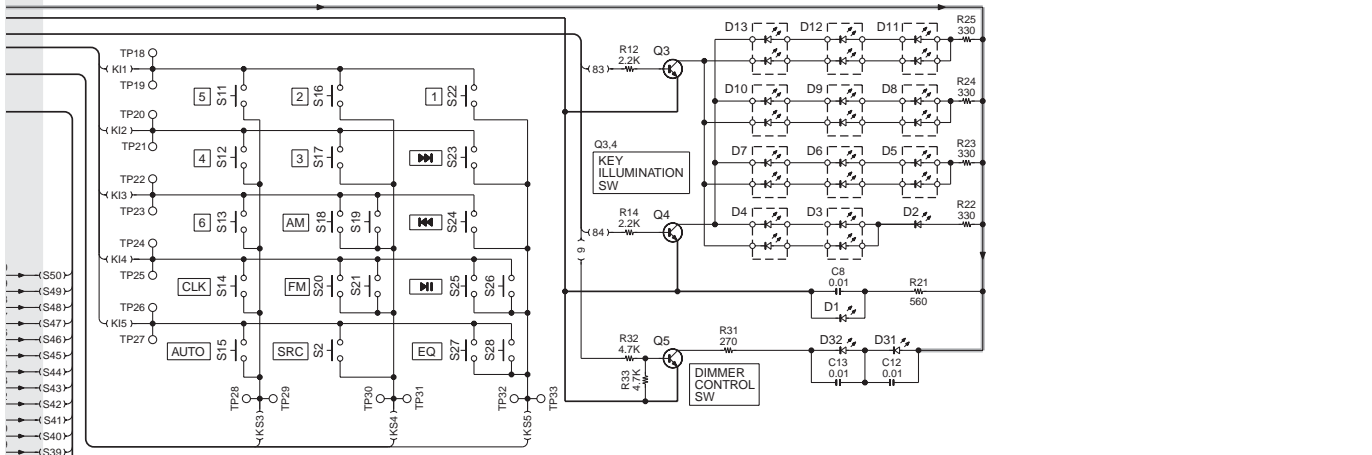
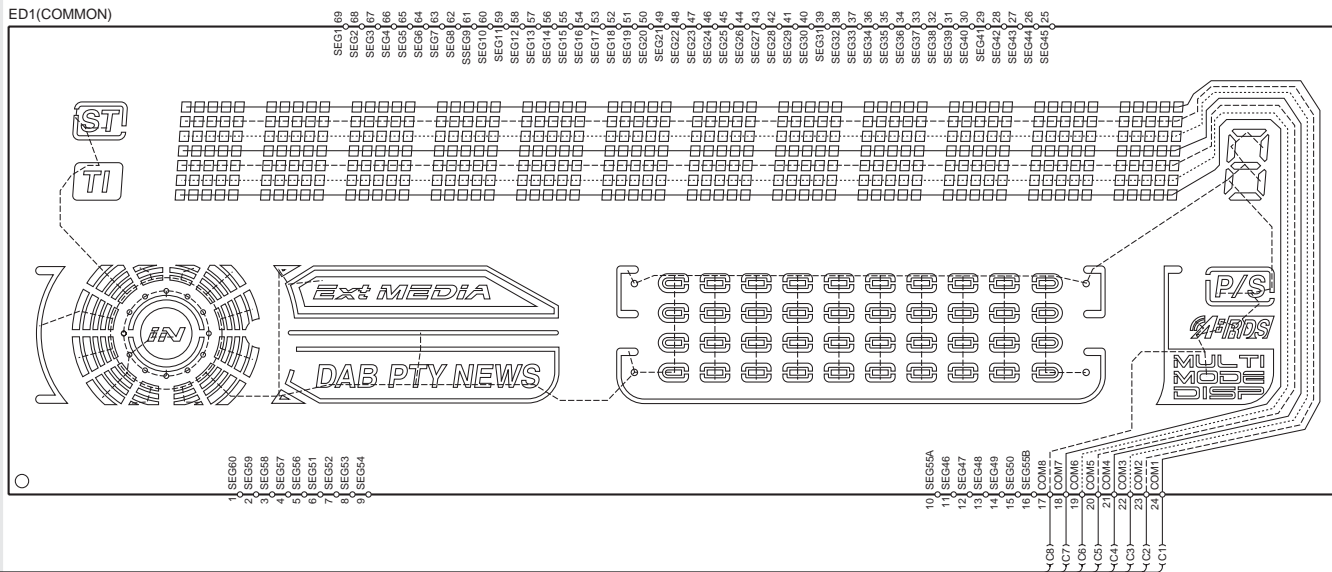

- IC1 : LC75808W
 - IC2 : PNA4S22M
 - Q2 : DTA114EE
 - Q3-5 : 2SC4617
 - D1 : B30-1564-05
 - D2 : B30-1566-05
 - D3 : B30-1692-05
 - D4-13 : B30-1605-05
 - D21 : MA3082-M
 - D31,32 : B30-1571-05
- GND LINE
— +B LINE

KDC-MP425/W6027/W6027Y/MP6026 (2/2)

DTA114EE
DTC143TUA
2SA1036K
2SA1576A
2SC4617



2SC4081

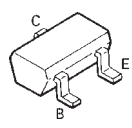

DTA124EUA
DTC144EUA

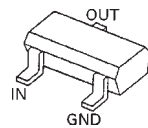

UMC2N

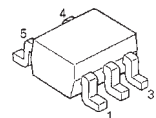

DAN202U



DAP202U
DA204K
DA204U
DTA114YUA

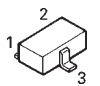

TC7SH08FU

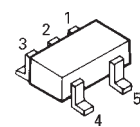

KDC-MP425/MP6026 KDC-W6027/W6027Y

CD PLAYER UNIT (X32-5500-00/01)

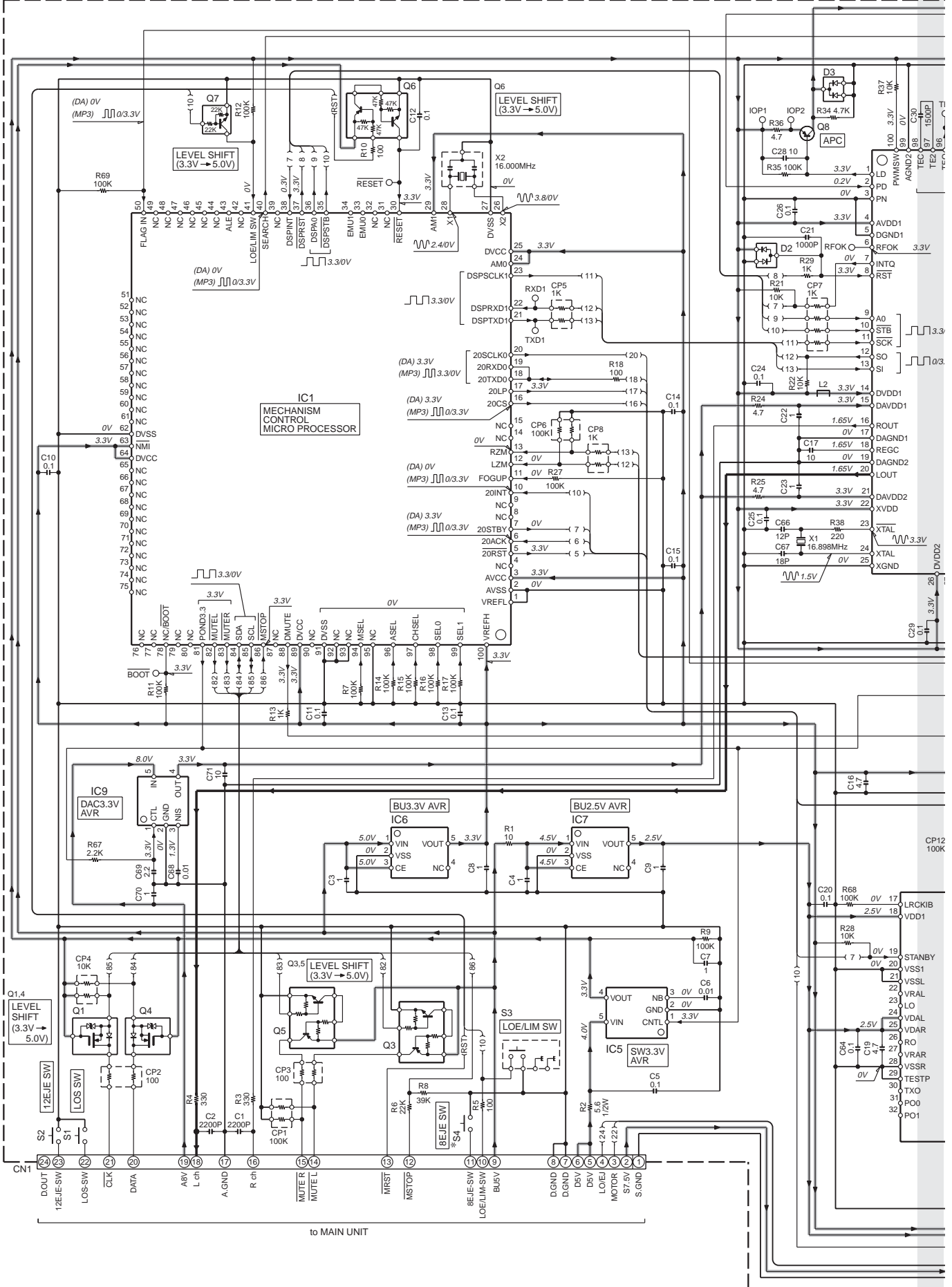

to MAIN UNIT

KDC-MP425/MP6026 KDC-W6027/W6027Y

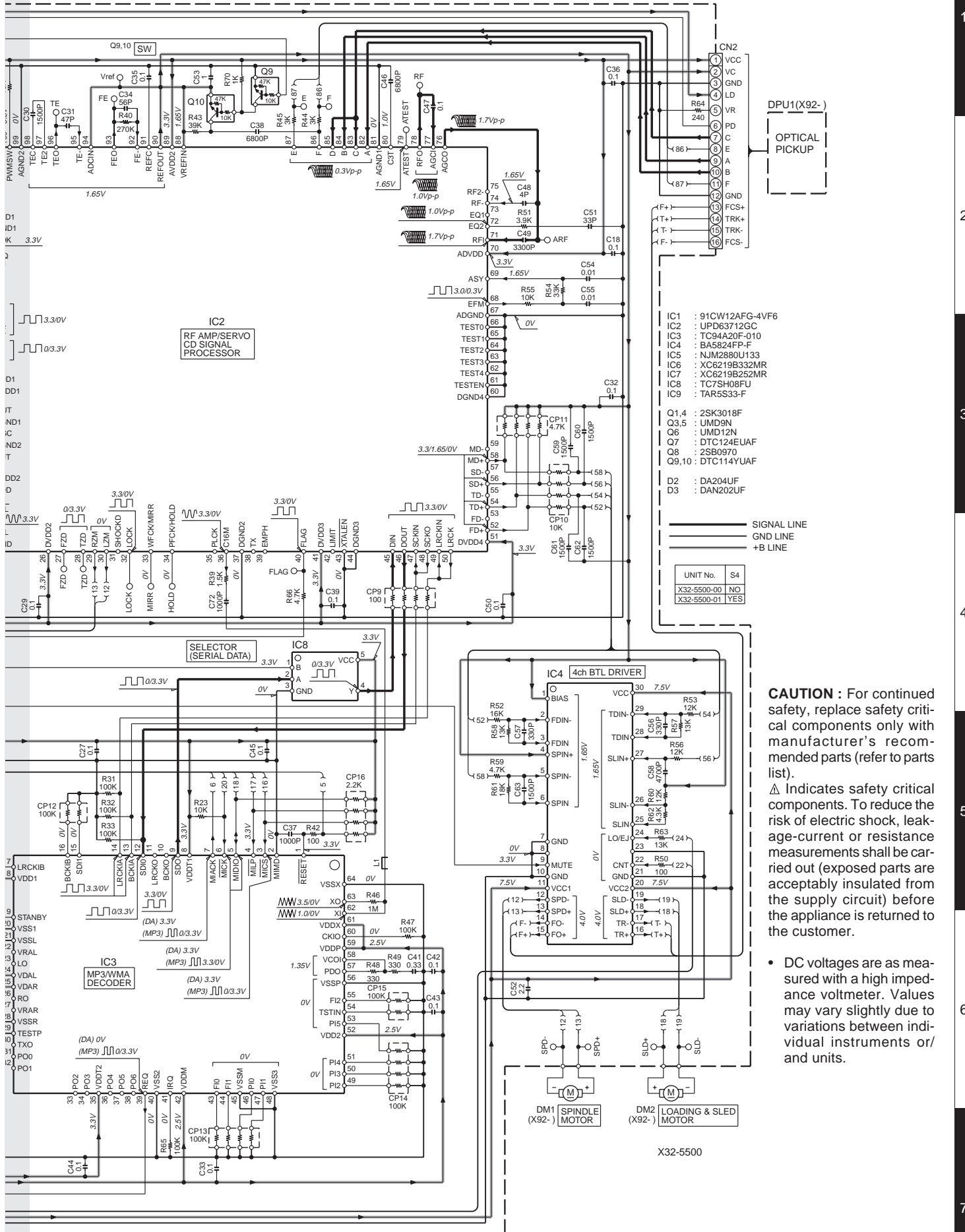

CAUTION : For continued safety, replace safety critical components only with manufacturer's recommended parts (refer to parts list).

⚠ Indicates safety critical components. To reduce the risk of electric shock, leakage-current or resistance measurements shall be carried out (exposed parts are acceptably insulated from the supply circuit) before the appliance is returned to the customer.

- DC voltages are as measured with a high impedance voltmeter. Values may vary slightly due to variations between individual instruments or/and units.

EXPLODED VIEW (UNIT)

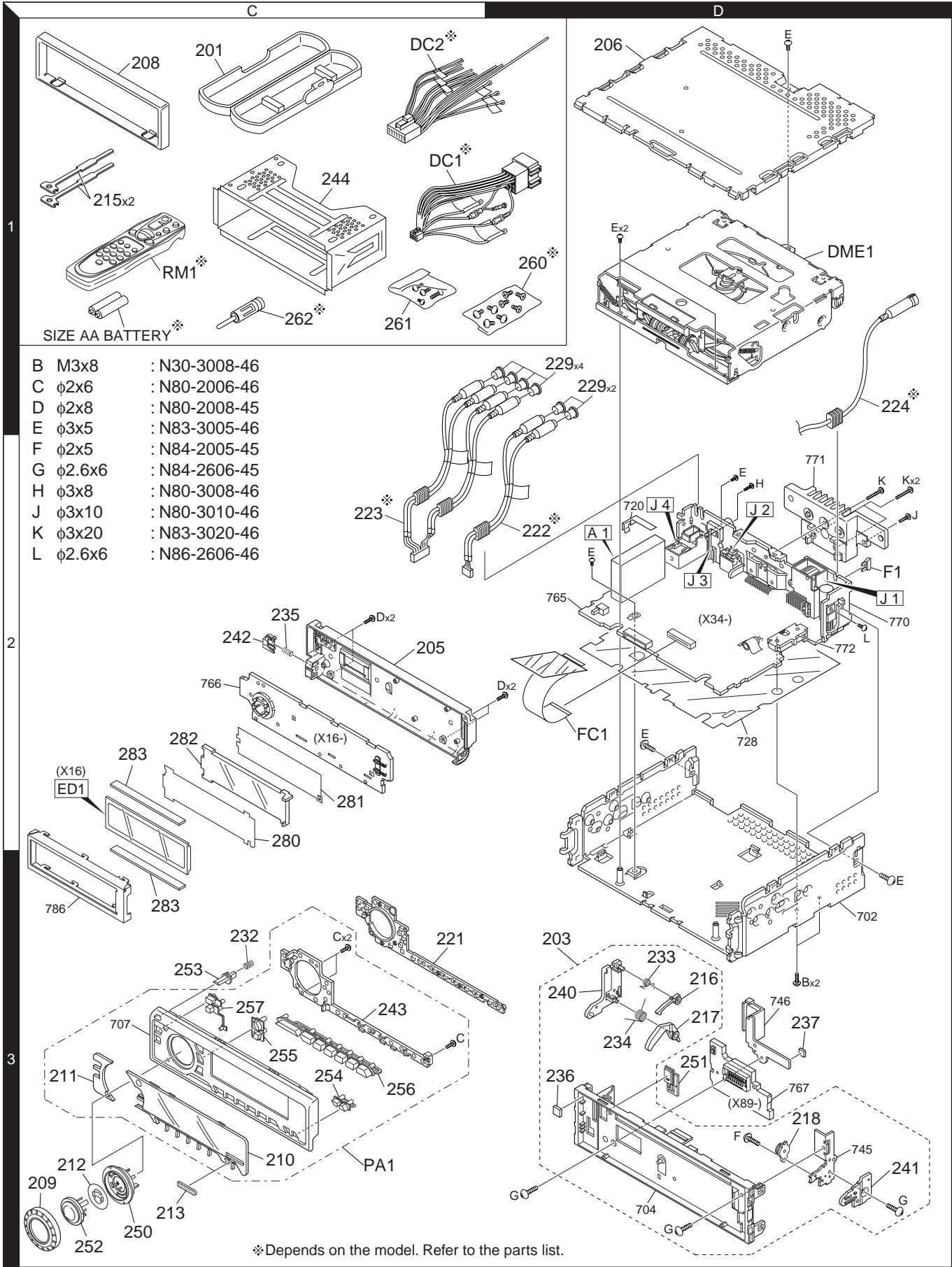

*Depends on the model. Refer to the parts list.

Parts with the exploded numbers larger than 700 are not supplied.

PARTS LIST

* New parts

Parts without **Parts No.** are not supplied.

Les articles non mentionnés dans le **Parts No.** ne sont pas fournis.

Teile ohne **Parts No.** werden nicht geliefert.

Ref. No.	A d d	N e w	Parts No.	Description	Desti- nation
KDC-MP425/MP6026/W6027/W6027Y					
201	1C		A02-1486-13	PLASTIC CABINET ASSY	
203	3D		A22-2982-22	SUB PANEL ASSY	
205	2C		A46-1797-01	REAR COVER	
206	1D		A52-0829-02	TOP PLATE	
PA1	3C	*	A64-3187-12	PANEL ASSY	K4
PA1	3C	*	A64-3194-12	PANEL ASSY	M3
PA1	3C	*	A64-3197-12	PANEL ASSY	E2E3
RM1	1C		A70-2040-05	REMOTE CONTROLLER ASSY (RC-505)	K4M3
-			B46-0100-50	WARRANTY CARD	K4M3E2
-			B46-0606-04	ID CARD	K4
-			B46-0612-14	ID CARD	M3E2E3
-			B46-0653-03	USER CARD	K4
-		*	B64-2695-00	INSTRUC. MANUAL (ENG.FRE.SPA.)	K4
-		*	B64-2699-00	INSTRUC. MANUAL (ENG.T-CHI.)	M3
-		*	B64-2700-00	INSTRUCTION MANUAL (ARABIC)	M3
-		*	B64-2704-00	INSTRUCTION MANUAL (ENGLISH)	E2E3
-		*	B64-2705-00	INSTRUC. MANUAL (FRE.GER.DUT.)	E2
-		*	B64-2706-00	INSTRUC. MANUAL (ITA.SPA.POR.)	E2
-		*	B64-2711-00	INSTRUC. MANUAL (CZE.HUN.CRO.)	E3
-		*	B64-2712-00	INSTRUC. MANUAL (SWE.FIN.SLO.)	E3
-		*	B64-2724-00	INSTRUCTION MANUAL (RUS.POL.)	E3
208	1C		B07-3083-02	ESCUTCHEON	M3E2E3
208	1C		B07-3098-02	ESCUTCHEON (SILVER)	K4
209	3C		B09-0533-03	CAP (ROTARY)	
210	3C	*	B10-4475-11	FRONT GLASS	K4
210	3C	*	B10-4482-11	FRONT GLASS	M3
210	3C	*	B10-4485-11	FRONT GLASS	E2E3
211	3C	*	B10-4494-12	FRONT GLASS	M3E2E3
211	3C	*	B10-4495-12	FRONT GLASS	K4
212	3C		B11-1440-04	OPTICAL DIFFUSER	
213	3C		B43-1518-04	BADGE	
215	1C		D10-4589-04	LEVER	
216	3D		D10-4730-03	LEVER (LOCK)	
217	3D		D10-4731-03	LEVER (PUSH)	
218	3D		D39-0255-05	DAMPER	
221	3C		E29-1967-02	CONDUCTIVE RUBBER	
222	1D		E30-6229-05	CORD WITH PINPLUG (1PRE FRONT)	K4E2E3
223	1D	*	E30-6278-05	CORD WITH PINPLUG (FRONT&AUX)	M3
224	1D		E30-6223-05	CORD WITH DIN CONNECTOR (OPEL)	E2E3
△ DC1	1C		E30-4958-05	DC CORD	E2E3
△ DC2	1C		E30-6295-05	DC CORD	K4M3
FC1	2D		E39-0438-05	FLAT CABLE (24PIN)	
229	1D		F29-0626-04	INSULATING COVER	
△ F1	2D		F52-0006-05	FUSE (MINI BLADE TYPE) (10A)	
232	3C		G01-3203-04	COMPRESSION SPRING	
233	3D		G01-3171-04	TORSION COIL SPRING (LOCK)	
234	3D		G01-3172-04	TORSION COIL SPRING (PUSH)	
235	2C		G01-3173-04	COMPRESSION SPRING (REAR COVER)	
236	3D		G13-1267-04	CUSHION	
237	3D		G13-1273-04	CUSHION	

Ref. No.	A d d	N e w	Parts No.	Description	Desti- nation
-			H10-4856-12	POLYSTYRENE FOAMED FIXTURE	
-			H13-2043-04	CARTON BOARD	
-			H25-0329-04	PROTECTION BAG (280X450X0.03)	K4M3E3
-			H25-0337-04	PROTECTION BAG (180X300X0.03)	
-			H25-1111-04	PROTECTION BAG (280X450X0.03)	E2
-		*	H54-3007-03	ITEM CARTON CASE	K4
-		*	H54-3014-03	ITEM CARTON CASE	M3
-		*	H54-3017-03	ITEM CARTON CASE	E2
-		*	H54-3021-03	ITEM CARTON CASE	E3
240	3D		J19-5203-03	HOLDER (LEFT)	
241	3D		J19-5204-03	HOLDER (RIGHT)	
242	2C		J19-5205-03	HOLDER (REAR COVER)	
243	3C		J19-5271-02	HOLDER	
244	1D		J22-0011-03	MOUNTING HARDWARE ASSY	
250	3C		K23-1081-03	KNOB (ROTARY)	
251	3D		K24-4000-03	KNOB (EJECT)	
252	3C		K24-4102-03	KNOB (SRC)	
253	3C		K24-4103-04	KNOB (REL)	
254	3C		K25-1593-03	KNOB (AUTO/CLK)	
255	3C		K25-1594-03	KNOB (PLAY/Q)	
256	3C		K25-1641-02	KNOB (PRESET)	
257	3C		K25-1642-03	KNOB (FM/AM)	
260	1C		N99-1719-05	SCREW SET	K4M3
261	1C		N99-1730-15	SCREW SET	
B	3D		N30-3008-46	PAN HEAD MACHINE SCREW (M3X 8)	
C	3C		N80-2006-46	PAN HEAD TAPTITE SCREW (2X 6)	
D	2C		N80-2008-45	PAN HEAD TAPTITE SCREW (2X 8)	
E	1D		N83-3005-46	PAN HEAD TAPTITE SCREW (3X 5)	
F	3D		N84-2005-45	PAN HEAD TAPTITE SCREW	
G	3D		N84-2606-45	PAN HEAD TAPTITE SCREW (2.6X6)	
262	1C		T90-0523-05	ANTENNA ADAPTOR	E2E3
DME1	1D		X92-4850-00	CD MECHANISM ASSY (DXM-6540W)	
SWITCH UNIT (X16-2490-10)					
280	2D		B11-1439-04	OPTICAL DIFFUSER	
281	2D		B11-1441-04	REFLECTION SHEET	
282	2D		B19-2243-02	LIGHTING BOARD	
D1			B30-1564-05	LED (1608,BLUE)	
D2			B30-1566-05	LED (1608,RED)	
D3			B30-1692-05	LED (HR/YG)	
D4-13			B30-1605-05	LED (2COLOR PG/RED)	
D31,32			B30-1571-05	LED (WHITE)	
ED1		*	B38-1134-05	LIQUID CRYSTAL	
C1			CK73GB1H102K	CHIP C 1000PF	K
C2-4			CK73GB1C104K	CHIP C 0.10UF	K
C6			CK73GB1H103K	CHIP C 0.010UF	K
C7			CK73FB1A225K	CHIP C 2.2UF	K
C8			CK73GB1H103K	CHIP C 0.010UF	K
C10-13			CK73GB1H103K	CHIP C 0.010UF	K
283	2D		E29-1968-04	CONDUCTIVE RUBBER	
J1			E59-0829-05	RECTANGULAR PLUG	
CP1			R90-0714-05	MULTI-COMP 10K X4	

K4 : KDC-MP425 M3 : KDC-MP6026 E2 : KDC-W6027 E3 : KDC-W6027Y

△ Indicates safety critical components.

PARTS LIST

* New parts

Parts without **Parts No.** are not supplied.

Les articles non mentionnés dans le **Parts No.** ne sont pas fournis.

Teile ohne **Parts No.** werden nicht geliefert.

SWITCH UNIT (X16-2490-10)

Ref. No.	Add	New	Parts No.	Description	Destination	Ref. No.	Add	New	Parts No.	Description	Destination
CP2			R90-1016-05	MULTI-COMP 470 X4		C50			CK73GB1C104K	CHIP C 0.10UF K	
R1			RK73GB2A303J	CHIP R 30K J 1/10W		C51			CC73GCH1H330J	CHIP C 33PF J	
R2-5			RK73GB2A222J	CHIP R 2.2K J 1/10W		C52			CK73FB1A225K	CHIP C 2.2UF K	
R6			RK73GB2A473J	CHIP R 47K J 1/10W		C53			CK73GB0J105K	CHIP C 1.0UF K	
R7			RK73GB2A102J	CHIP R 1.0K J 1/10W		C54,55			CK73GB1H103K	CHIP C 0.010UF K	
R8			RK73GB2A4R7J	CHIP R 4.7 J 1/10W		C56,57			CK73GB1H331K	CHIP C 330PF K	
R9			RK73GB2A471J	CHIP R 470 J 1/10W		C58			CK73GB1H472K	CHIP C 4700PF K	
R10			RK73GB2A101J	CHIP R 100 J 1/10W		C59-63			CK73GB1H152K	CHIP C 1500PF K	
R11			RK73GB2A102J	CHIP R 1.0K J 1/10W		C64			CK73GB1C104K	CHIP C 0.10UF K	
R12			RK73GB2A222J	CHIP R 2.2K J 1/10W		C66			CC73GCH1H120J	CHIP C 12PF J	
R14			RK73GB2A222J	CHIP R 2.2K J 1/10W		C67			CC73GCH1H180J	CHIP C 18PF J	
R21			RK73FB2B561J	CHIP R 560 J 1/8W		C68			CK73GB1H103K	CHIP C 0.010UF K	
R22-25			RK73FB2B331J	CHIP R 330 J 1/8W		C69			CK73FB1A225K	CHIP C 2.2UF K	
R31			RK73FB2B271J	CHIP R 270 J 1/8W		C70			CK73FB1A105K	CHIP C 1.0UF K	
R32,33			RK73GB2A472J	CHIP R 4.7K J 1/10W		C71			CK73FB0J106M	CHIP C 10UF M	
S2			S70-0814-05	TACT SWITCH		C72			CK73GB1H102K	CHIP C 1000PF K	
S1			T99-0449-05	ROTARY ENCODER		CN1			E41-2083-05	FLAT CABLE CONNECTOR	
D21			MA3082-M	ZENER DIODE		CN2			E41-2068-05	FLAT CABLE CONNECTOR	
IC1			LC75808W	MOS-IC		CN2			E41-2085-05	FLAT CABLE CONNECTOR	
IC2			PNA4S22M	ANALOGUE IC		L1,2			L92-0386-05	CHIP FERRITE	
Q2			DTA114EE	DIGITAL TRANSISTOR		X1			L77-2808-05	CRYSTAL RESONATOR (16.897849MHZ)	
Q3-5			2SC4617	TRANSISTOR		X2			L78-0896-05	RESONATOR (16.00MHZ)	
CD PLAYER UNIT (X32-5500-00)						CP1			RK74GA1J104J	CHIP-COM 100K J 1/16W	
C1,2			CK73GB1H222K	CHIP C 2200PF K		CP2,3			RK74GA1J101J	CHIP-COM 100 J 1/16W	
C3,4			CK73GB0J105K	CHIP C 1.0UF K		CP4			RK74GA1J103J	CHIP-COM 10K J 1/16W	
C5			CK73GB1C104K	CHIP C 0.10UF K		CP5			RK74GA1J102J	CHIP-COM 1.0K J 1/16W	
C6			CK73GB1H103K	CHIP C 0.010UF K		CP6			RK74GA1J104J	CHIP-COM 100K J 1/16W	
C7-9			CK73GB0J105K	CHIP C 1.0UF K		CP7			RK74GB1J102J	CHIP-COM 1.0K J 1/16W	
C10-15			CK73GB1C104K	CHIP C 0.10UF K		CP8			RK74GA1J102J	CHIP-COM 1.0K J 1/16W	
C16			CK73FB0J475K	CHIP C 4.7UF K		CP9			RK74GB1J101J	CHIP-COM 100 J 1/16W	
C17			CK73FB0J106M	CHIP C 10UF M		CP10			RK74GB1J103J	CHIP-COM 10K J 1/16W	
C18			CK73GB1C104K	CHIP C 0.10UF K		CP11			RK74GB1J472J	CHIP-COM 4.7K J 1/16W	
C19			CK73FB0J475K	CHIP C 4.7UF K		CP12			RK74GA1J104J	CHIP-COM 100K J 1/16W	
C20			CK73GB1C104K	CHIP C 0.10UF K		CP13,14			RK74GB1J104J	CHIP-COM 100K J 1/16W	
C21			CK73GB1H102K	CHIP C 1000PF K		CP15			RK74GA1J104J	CHIP-COM 100K J 1/16W	
C22,23			CK73GB0J105K	CHIP C 1.0UF K		CP16			RK74GB1J222J	CHIP-COM 2.2K J 1/16W	
C24-27			CK73GB1C104K	CHIP C 0.10UF K		R1			RK73GB2A100J	CHIP R 10 J 1/10W	
C28			CK73FB0J106M	CHIP C 10UF M		R2			R92-3494-05	METAL GLAZE RESISTOR	
C29			CK73GB1C104K	CHIP C 0.10UF K		R3,4			RK73FB2B331J	CHIP R 330 J 1/8W	
C30			CK73GB1H152K	CHIP C 1500PF K		R5			RK73GB2A101J	CHIP R 100 J 1/10W	
C31			CC73GCH1H470J	CHIP C 47PF J		R6			RN73GH1J223D	CHIP R 22K D 1/16W	
C32,33			CK73GB1C104K	CHIP C 0.10UF K		R7			RK73GB2A104J	CHIP R 100K J 1/10W	
C34			CC73GCH1H560J	CHIP C 56PF J		R8			RN73GH1J393D	CHIP R 39K D 1/16W	
C35,36			CK73GB1C104K	CHIP C 0.10UF K		R9			RK73GB2A104J	CHIP R 100K J 1/10W	
C37			CK73GB1H102K	CHIP C 1000PF K		R10			RK73GB2A101J	CHIP R 100 J 1/10W	
C38			CK73GB1H682K	CHIP C 6800PF K		R11,12			RK73GB2A104J	CHIP R 100K J 1/10W	
C39			CK73GB1C104K	CHIP C 0.10UF K		R13			RK73GB2A102J	CHIP R 1.0K J 1/10W	
C41			CK73GB1A334K	CHIP C 0.33UF K		R14-17			RK73GB2A104J	CHIP R 100K J 1/10W	
C42-45			CK73GB1C104K	CHIP C 0.10UF K		R18			RK73GB2A101J	CHIP R 100 J 1/10W	
C46			CK73GB1H682K	CHIP C 6800PF K		R21-23			RK73GB2A103J	CHIP R 10K J 1/10W	
C47			CK73GB1C104K	CHIP C 0.10UF K		R24,25			RK73GB2A4R7J	CHIP R 4.7 J 1/10W	
C48			CC73GCH1H040C	CHIP C 4.0PF C		R27			RK73GB2A104J	CHIP R 100K J 1/10W	
C49			CK73GB1H332K	CHIP C 3300PF K		R28			RK73GB2A103J	CHIP R 10K J 1/10W	

K4 : KDC-MP425 M3 : KDC-MP6026 E2 : KDC-W6027 E3 : KDC-W6027Y

△ Indicates safety critical components.

PARTS LIST

* New parts

Parts without **Parts No.** are not supplied.

Les articles non mentionnés dans le **Parts No.** ne sont pas fournis.

Teile ohne **Parts No.** werden nicht geliefert.

CD PLAYER UNIT (X32-5500-00)

Ref. No.	A d d	N e w	Parts No.	Description	Desti- nation
R29			RK73GB2A102J	CHIP R 1.0K J 1/10W	
R31-33			RK73GB2A104J	CHIP R 100K J 1/10W	
R34			RK73GB2A472J	CHIP R 4.7K J 1/10W	
R35			RK73GB2A104J	CHIP R 100K J 1/10W	
R36			RK73FB2B4R7J	CHIP R 4.7 J 1/8W	
R37			RK73GB2A103J	CHIP R 10K J 1/10W	
R38			RK73GB2A221J	CHIP R 220 J 1/10W	
R39			RK73GB2A152J	CHIP R 1.5K J 1/10W	
R40			RK73GB2A274J	CHIP R 270K J 1/10W	
R42			RK73GB2A101J	CHIP R 100 J 1/10W	
R43			RK73GB2A393J	CHIP R 39K J 1/10W	
R44,45			RK73GB2A302J	CHIP R 3.0K J 1/10W	
R46			RK73GB2A105J	CHIP R 1.0M J 1/10W	
R47			RK73GB2A104J	CHIP R 100K J 1/10W	
R48,49			RK73GB2A331J	CHIP R 330 J 1/10W	
R50			RK73GB2A101J	CHIP R 100 J 1/10W	
R51			RK73GB2A392J	CHIP R 3.9K J 1/10W	
R52			RK73GB2A163J	CHIP R 16K J 1/10W	
R53			RK73GB2A123J	CHIP R 12K J 1/10W	
R54			RK73GB2A333J	CHIP R 33K J 1/10W	
R55			RK73GB2A103J	CHIP R 10K J 1/10W	
R56			RK73GB2A123J	CHIP R 12K J 1/10W	
R57,58			RK73GB2A133J	CHIP R 13K J 1/10W	
R59			RK73GB2A472J	CHIP R 4.7K J 1/10W	
R60			RK73GB2A123J	CHIP R 12K J 1/10W	
R61			RK73GB2A183J	CHIP R 18K J 1/10W	
R62			RK73GB2A432J	CHIP R 4.3K J 1/10W	
R63			RK73GB2A133J	CHIP R 13K J 1/10W	
R64			RK73GB2A241J	CHIP R 240 J 1/10W	
R65			RK73GB2A104J	CHIP R 100K J 1/10W	
R66			RK73GB2A472J	CHIP R 4.7K J 1/10W	
R67			RK73GB2A222J	CHIP R 2.2K J 1/10W	
R68,69			RK73GB2A104J	CHIP R 100K J 1/10W	
R70			RK73GB2A102J	CHIP R 1.0K J 1/10W	
S1,2			S68-0863-05	PUSH SWITCH	
S3			S68-0862-05	PUSH SWITCH	
D2			DA204UF	DIODE	
D3			DAN202UF	DIODE	
IC1			91CW12AFG-4VF6	MICROCONTROLLER IC	
IC2			UPD63712GC	MOS-IC	
IC3			TC94A20F-010	MOS-IC	
IC4			BA5824FP-F	ANALOGUE IC	
IC5			NJM2880U133	ANALOGUE IC	
IC5			NJM2880U33	ANALOGUE IC	
IC6			S-1112B33MCG	ANALOGUE IC	
IC6			XC6219B332MR	ANALOGUE IC	
IC7			S-1112B25MCG	ANALOGUE IC	
IC7			XC6219B252MR	ANALOGUE IC	
IC8			TC7SH08FU	MOS-IC	
IC9			TAR5S33-F	ANALOGUE IC	
Q1			2SK3018F	FET	
Q3			UMD9N	TRANSISTOR	
Q4			2SK3018F	FET	
Q5			UMD9N	TRANSISTOR	

Ref. No.	A d d	N e w	Parts No.	Description	Desti- nation
Q6			UMD12N	TRANSISTOR	
Q7			DTC124EUAF	DIGITAL TRANSISTOR	
Q8			2SB0970	TRANSISTOR	
Q9,10			DTC114YUAF	DIGITAL TRANSISTOR	
ELECTRIC UNIT (X34-308x-xx)					
C1			C94-0213-05	ELECTRO 2200UF 16WV	
C2			CK73GB1H103K	CHIP C 0.010UF K	
C3			CK73GB1H102K	CHIP C 1000PF K	
C4-6			CK73GB1H103K	CHIP C 0.010UF K	
C21			CD04AS1A101M	ELECTRO 100UF 10WV	
C22			CD04AS1E100M	ELECTRO 10UF 25WV	E2E3
C22,23			CD04AS1E100M	ELECTRO 10UF 25WV	K4M3
C24,25			CD04AS1C100M	ELECTRO 10UF 16WV	
C26			CD04AS1E100M	ELECTRO 10UF 25WV	
C27			CD04AT1H100M	ELECTRO 10UF 50WV	
C28			C90-5635-05	ELECTRO 220UF 16WV	
C29			CD04AS1C100M	ELECTRO 10UF 16WV	
C31			CK73GB1H103K	CHIP C 0.010UF K	
C32			CK73GB1E223K	CHIP C 0.022UF K	
C33			CD04AS1H010M	ELECTRO 1UF 50WV	
C41,42			CD04BF1E101M	ELECTRO 100UF 25WV	
C43,44			CD04BF1C221M	ELECTRO 220UF 16WV	
C45			CK73GB1A224K	CHIP C 0.22UF K	
C51,52			CK73GB1H103K	CHIP C 0.010UF K	
C111			CK73GB1H102K	CHIP C 1000PF K	
C112,113			CC73GCH1H270J	CHIP C 27PF J	E2E3
C114			CK73GB1H103K	CHIP C 0.010UF K	E2E3
C115			CD04AS1C100M	ELECTRO 10UF 16WV	E2E3
C116			CC73GCH1H331J	CHIP C 330PF J	E2E3
C117			CD04AS1H2R2M	ELECTRO 2.2UF 50WV	E2E3
C118			CC73GCH1H681J	CHIP C 680PF J	E2E3
C119			CK73GB1H103K	CHIP C 0.010UF K	
C163			CK73GB1H103K	CHIP C 0.010UF K	
C201,202			CD04AS1HR47M	ELECTRO 0.47UF 50WV	
C203			CK73GB1H223K	CHIP C 0.022UF K	
C204			CK73GB1H103K	CHIP C 0.010UF K	
C205			CK73GB1A474K	CHIP C 0.47UF K	
C206			CC73GCH1H151J	CHIP C 150PF J	
C207,208			CD04AS1H010M	ELECTRO 1UF 50WV	M3
C209			CD04AS1H2R2M	ELECTRO 2.2UF 50WV	
C210			CK73GB1H103K	CHIP C 0.010UF K	
C211			CD04AS1A470M	ELECTRO 47UF 10WV	
C212,213			CK73GB1C104K	CHIP C 0.10UF K	
C214,215			CK73GB1H103K	CHIP C 0.010UF K	
C216,217			CD04AS1H010M	ELECTRO 1UF 50WV	
C218-221			CD04AS1H0R1M	ELECTRO 0.1UF 50WV	
C251-254			C94-0179-05	ELECTRO 0.22UF 50WV	
C255			CD04AS1H010M	ELECTRO 1UF 50WV	
C256			CD04AS1C220M	ELECTRO 22UF 16WV	
C257			CK73GB1A105K	CHIP C 1.0UF K	
C258			C94-0048-05	ELECTRO 0.22UF 50WV	
C301,302			CD04AS1HR47M	ELECTRO 0.47UF 50WV	
C303			CD04AS1A470M	ELECTRO 47UF 10WV	
C304			CK73GB1H103K	CHIP C 0.010UF K	
C351-354			CD04AS1C100M	ELECTRO 10UF 16WV	

PARTS LIST

* New parts

Parts without **Parts No.** are not supplied.

Les articles non mentionnés dans le **Parts No.** ne sont pas fournis.

Teile ohne **Parts No.** werden nicht geliefert.

ELECTRIC UNIT (X34-308x-xx)

Ref. No.	Add	New	Parts No.	Description	Destination	Ref. No.	Add	New	Parts No.	Description	Destination
C355			CD04AS1A470M	ELECTRO 47UF 10WV	M3	R33			RK73GB2A473J	CHIP R 47K J 1/10W	
C356,357			CK73GB1H103K	CHIP C 0.010UF K		R34			RK73EB2E103J	CHIP R 10K J 1/4W	
C358,359			CD04AS1HR47M	ELECTRO 0.47UF 50WV	M3	R35			RK73GB2A104J	CHIP R 100K J 1/10W	
C360			CK73GB1H103K	CHIP C 0.010UF K	M3	R36			RK73GB2A222J	CHIP R 2.2K J 1/10W	
C401-404			CK73GB1H103K	CHIP C 0.010UF K		R41-44			RK73GB2A473J	CHIP R 47K J 1/10W	
C405			CK73GB0J105K	CHIP C 1.0UF K		R51,52			RK73GB2A222J	CHIP R 2.2K J 1/10W	
C406			CK73GB1C104K	CHIP C 0.10UF K		R53-56			RK73GB2A102J	CHIP R 1.0K J 1/10W	
C407			CC73GCH1H220J	CHIP C 22PF J		R58			RK73GB2A222J	CHIP R 2.2K J 1/10W	
C408			CC73GCH1H270J	CHIP C 27PF J		R59			RK73GB2A101J	CHIP R 100 J 1/10W	
C409			CD04AT0J470M	ELECTRO 47UF 6.3WV		R60			RK73GB2A222J	CHIP R 2.2K J 1/10W	
C500			CK73FB1A225K	CHIP C 2.2UF K		R61,62			RK73GB2A104J	CHIP R 100K J 1/10W	
C501,502			CK73GB1H103K	CHIP C 0.010UF K		R63			RK73GB2A222J	CHIP R 2.2K J 1/10W	
C503			CK73GB1H472K	CHIP C 4700PF K		R64,65			RK73GB2A104J	CHIP R 100K J 1/10W	
CN1			E41-0167-05	PIN ASSY		R67,68			RK73GB2A471J	CHIP R 470 J 1/10W	
CN2			E41-0168-05	FLAT CABLE CONNECTOR		R101			RK73GB2A102J	CHIP R 1.0K J 1/10W	
CN3			E40-3238-05	PIN ASSY	K4E2E3	R102			RK73GB2A471J	CHIP R 470 J 1/10W	
CN4			E40-3241-05	PIN ASSY	M3	R103			RK73GB2A472J	CHIP R 4.7K J 1/10W	
CN5			E40-3260-05	PIN ASSY	K4E2E3	R104			RK73GB2A471J	CHIP R 470 J 1/10W	
CN6			E40-3261-05	PIN ASSY	K4E2E3	R105			RK73GB2A472J	CHIP R 4.7K J 1/10W	
△ J1			E58-0863-15	RECTANGULAR RECEPTACLE		R106			RK73GB2A222J	CHIP R 2.2K J 1/10W	
J2			E56-0834-05	CYLINDRICAL RECEPTACLE		R111			RK73GB2A472J	CHIP R 4.7K J 1/10W	E2E3
J3			E63-0887-05	PIN JACK		R112-115			RK73GB2A222J	CHIP R 2.2K J 1/10W	E2E3
J4			E04-0312-05	RF COAXIAL CABLE RECEPTACLE		R152			RK73GB2A102J	CHIP R 1.0K J 1/10W	
L1			L33-1170-05	CHOKE COIL ASSY		R153			RK73GB2A471J	CHIP R 470 J 1/10W	
L3			L33-1123-05	LINE FILTER COIL		R154			RK73GB2A102J	CHIP R 1.0K J 1/10W	
L6-11			L40-4795-91	SMALL FIXED INDUCTOR (4.7UH,J)	E2E3	R155			RK73GB2A222J	CHIP R 2.2K J 1/10W	
L6-8			L40-4795-91	SMALL FIXED INDUCTOR (4.7UH,J)	K4M3	R157,158			RK73GB2A471J	CHIP R 470 J 1/10W	
L10,11			L40-4795-91	SMALL FIXED INDUCTOR (4.7UH,J)	K4M3	R159			RK73GB2A102J	CHIP R 1.0K J 1/10W	
L12			L33-1925-05	CHOKE COIL		R160			RK73GB2A222J	CHIP R 2.2K J 1/10W	
X1			L78-0821-05	RESONATOR		R161			RK73GB2A225J	CHIP R 2.2M J 1/10W	
X2			L77-2738-05	CRYSTAL RESONATOR		R162,163			RK73GB2A104J	CHIP R 100K J 1/10W	
X3			L77-2002-05	CRYSTAL RESONATOR	E2E3	R164,165			RK73GB2A473J	CHIP R 47K J 1/10W	
E	2D		N83-3005-46	PAN HEAD TAPTITE SCREW		R166			RK73GB2A472J	CHIP R 4.7K J 1/10W	
H	2D		N80-3008-46	PAN HEAD TAPTITE SCREW		R167			RK73GB2A474J	CHIP R 470K J 1/10W	
J	2D		N80-3010-46	PAN HEAD TAPTITE SCREW		R168,169			RK73GB2A102J	CHIP R 1.0K J 1/10W	
K	2D		N83-3020-46	PAN HEAD TAPTITE SCREW		R185,186			RK73GB2A474J	CHIP R 470K J 1/10W	
L	2D		N86-2606-46	BINDING HEAD TAPTITE SCREW		R187			RK73GB2A222J	CHIP R 2.2K J 1/10W	
R1			RK73GB2A823J	CHIP R 82K J 1/10W		R188			RK73GB2A473J	CHIP R 47K J 1/10W	
R2			RK73GB2A363J	CHIP R 36K J 1/10W		R201			RK73GB2A103J	CHIP R 10K J 1/10W	
R3			RK73GB2A104J	CHIP R 100K J 1/10W		R202-204			RK73GB2A472J	CHIP R 4.7K J 1/10W	
R4			RK73FB2B203J	CHIP R 20K J 1/8W		R205			RK73GB2A222J	CHIP R 2.2K J 1/10W	
R5,6			RK73GB2A103J	CHIP R 10K J 1/10W		R206-208			RK73GB2A102J	CHIP R 1.0K J 1/10W	E2E3
R7			RK73GB2A223J	CHIP R 22K J 1/10W		R207,208			RK73GB2A102J	CHIP R 1.0K J 1/10W	K4M3
R8			RD14DB2H332J	SMALL-RD 3.3K J 1/2W		R209,210			RK73GB2A103J	CHIP R 10K J 1/10W	
R9			RD14BB2C333J	RD 33K J 1/6W		R211,212			RK73GB2A333J	CHIP R 33K J 1/10W	
R10,11			RK73GB2A223J	CHIP R 22K J 1/10W		R251			RK73GB2A473J	CHIP R 47K J 1/10W	
R12			RK73GB2A473J	CHIP R 47K J 1/10W		R253			RK73GB2A432J	CHIP R 4.3K J 1/10W	
R13			RK73GB2A562J	CHIP R 5.6K J 1/10W		R254			RK73GB2A100J	CHIP R 10 J 1/10W	
R21			RK73FB2B152J	CHIP R 1.5K J 1/8W		R255			RK73GB2A331J	CHIP R 330 J 1/10W	
R22,23			RD14BB2C472J	RD 4.7K J 1/6W		R256			RK73GB2A334J	CHIP R 330K J 1/10W	
R24-28			RK73GB2A103J	CHIP R 10K J 1/10W	K4M3	R257			RK73GB2A153J	CHIP R 15K J 1/10W	
R25-28			RK73GB2A103J	CHIP R 10K J 1/10W	E2E3	R301,302			RK73EB2E100J	CHIP R 10 J 1/4W	
R31			RK73EB2E103J	CHIP R 10K J 1/4W		R303			RK73EB2E101J	CHIP R 100 J 1/4W	
R32			RK73GB2A223J	CHIP R 22K J 1/10W		R304,305			RK73EB2E472J	CHIP R 4.7K J 1/4W	
						R306			RK73EB2E4R7J	CHIP R 4.7 J 1/4W	

K4 : KDC-MP425 M3 : KDC-MP6026 E2 : KDC-W6027 E3 : KDC-W6027Y

△ Indicates safety critical components.

PARTS LIST

* New parts

Parts without **Parts No.** are not supplied.

Les articles non mentionnés dans le **Parts No.** ne sont pas fournis.

Teile ohne **Parts No.** werden nicht geliefert.

ELECTRIC UNIT (X34-308x-xx)

Ref. No.	A d d	N e w	Parts No.	Description	Desti- nation
R307-309			RK73EB2E472J	CHIP R 4.7K J 1/4W	
R310,311			RK73EB2E101J	CHIP R 100 J 1/4W	
R312-315			RK73GB2A104J	CHIP R 100K J 1/10W	
R351,352			RK73GB2A361J	CHIP R 360 J 1/10W	
R355,356			RK73GB2A223J	CHIP R 22K J 1/10W	
R357,358			RK73EB2E181J	CHIP R 180 J 1/4W	
R359,360			RK73GB2A361J	CHIP R 360 J 1/10W	
R361,362			RK73GB2A223J	CHIP R 22K J 1/10W	
R363,364			RK73EB2E181J	CHIP R 180 J 1/4W	
R365			RK73FB2B4R7J	CHIP R 4.7 J 1/8W	M3
R366-368			RK73FB2B471J	CHIP R 470 J 1/8W	K4E2E3
R369			RK73EB2E471J	CHIP R 470 J 1/4W	K4E2E3
R370-372			RK73GB2A101J	CHIP R 100 J 1/10W	K4E2E3
R373			RK73GB2A102J	CHIP R 1.0K J 1/10W	M3
R378,379			RK73FB2B100J	CHIP R 10 J 1/8W	M3
R401-406			RK73GB2A104J	CHIP R 100K J 1/10W	
R407			RK73GB2A223J	CHIP R 22K J 1/10W	
R408			RK73GB2A104J	CHIP R 100K J 1/10W	
R409			RK73GB2A153J	CHIP R 15K J 1/10W	
R410			RK73GB2A104J	CHIP R 100K J 1/10W	
R411			RK73GB2A223J	CHIP R 22K J 1/10W	K4
R412			RK73GB2A223J	CHIP R 22K J 1/10W	M3E2E3
R415			RK73GB2A223J	CHIP R 22K J 1/10W	K4E2E3
R415,416			RK73GB2A223J	CHIP R 22K J 1/10W	M3
R417			RK73GB2A223J	CHIP R 22K J 1/10W	K4E2E3
R419			RK73GB2A223J	CHIP R 22K J 1/10W	K4
R419,420			RK73GB2A223J	CHIP R 22K J 1/10W	M3E2E3
R421			RK73GB2A223J	CHIP R 22K J 1/10W	K4
R422			RK73GB2A103J	CHIP R 10K J 1/10W	
W105-109			R92-1252-05	CHIP R 0 OHM J 1/16W	M3
W109			R92-1252-05	CHIP R 0 OHM J 1/16W	K4E2E3
W201-204			R92-1252-05	CHIP R 0 OHM J 1/16W	
S1			S74-0821-05	MICRO SWITCH	
D1			1N5393G-M6	DIODE	
D2-4			MA4068(N)-M	ZENER DIODE	
D21			MA4082(N)-L	ZENER DIODE	
D22-25			AM01ZNF	DIODE	
D26			DAN202U	DIODE	
D31			HZS5B1	ZENER DIODE	
D41			SFPB-54V	DIODE	
D151-155			DA204K	DIODE	
D157-162			DA204K	DIODE	
D163			MA4062-L	ZENER DIODE	
D164			MA4120-L	ZENER DIODE	
D165			MA4062-L	ZENER DIODE	
D166			DA204U	DIODE	
D203-205			DAP202U	DIODE	
D269			1SS133	DIODE	
D271			1SS133	DIODE	
D301			MA4062-L	ZENER DIODE	
D303,304			MA4062-L	ZENER DIODE	
D307,308			MA4062-L	ZENER DIODE	
D309-311			MA4068(N)-M	ZENER DIODE	

Ref. No.	A d d	N e w	Parts No.	Description	Desti- nation
D351			MA3062WA	ZENER DIODE	E2E3
D352			DA204U	DIODE	E2E3
D356			MA4062-L	ZENER DIODE	M3
D357,358			MA4068(N)-M	ZENER DIODE	M3
D359			DA204U	DIODE	M3
D401			1SS133	DIODE	
IC1			UPD703030GC044	MICROCONTROLLER IC	
IC2			TDA7411	ANALOGUE IC	
IC3			BA4911-V4	ANALOGUE IC	
IC4			TB2903H	ANALOGUE IC	
IC6			HD74HC27FP-E	MOS-IC	E2E3
IC7			SAA6581T	ANALOGUE IC	
IC8			PST3436UL	MOS-IC	
IC9			SI-8050JD	ANALOGUE IC	
Q1-3			2SC4081	TRANSISTOR	
Q4			2SA1036K	TRANSISTOR	
Q21			2SD2375	TRANSISTOR	
Q22			UMC2N	TRANSISTOR	E2E3
Q22,23			UMC2N	TRANSISTOR	K4M3
Q31			DTC144EUA	DIGITAL TRANSISTOR	
Q41			2SC4081	TRANSISTOR	E2E3
Q101			DTC143TUA	DIGITAL TRANSISTOR	
Q151			DTA114YUA	DIGITAL TRANSISTOR	
Q152			2SA1576A	TRANSISTOR	
Q153			DTC144EUA	DIGITAL TRANSISTOR	
Q154			2SA1577	TRANSISTOR	
Q201			DTC143TUA	DIGITAL TRANSISTOR	
Q350			DTA124EUA	DIGITAL TRANSISTOR	
Q351,352			DTC143TUA	DIGITAL TRANSISTOR	
Q354			DTA124EUA	DIGITAL TRANSISTOR	
Q355,356			DTC143TUA	DIGITAL TRANSISTOR	
TH1			PRF21BE471QB2	POSITIVE RESISTOR	
A1			X86-3720-11	FRONT-END UNIT	K4M3
A1			X86-3722-70	FRONT-END UNIT	E2E3
DAUGHTER UNIT (X89-2570-10)					
C1			CK73GB1H103K	CHIP C 0.010UF K	
CN1			E41-0169-05	SOCKET FOR PIN ASSY	
J1			E58-0865-05	RECTANGULAR RECEPTACLE	
R1			RK73EB2E102J	CHIP R 1.0K J 1/4W	
R2-5			RK73EB2E471J	CHIP R 470 J 1/4W	
R6,7			RK73EB2E102J	CHIP R 1.0K J 1/4W	
R8			RK73EB2E241J	CHIP R 240 J 1/4W	
R9,10			RK73EB2E471J	CHIP R 470 J 1/4W	
R11-13			RK73EB2E102J	CHIP R 1.0K J 1/4W	
S1			S70-0871-05	TACT SWITCH	
CD MECHANISM ASSY (X92-4850-00)					
2	1B		A10-4827-32	CHASSIS	
5	1B	*	D10-4576-73	ARM ASSY	
8	2A		D10-4579-13	LEVER ASSY	
10	2A		D10-4581-13	ARM	
11	2A		D10-4582-13	ARM	

PARTS LIST

* New parts

Parts without **Parts No.** are not supplied.

Les articles non mentionnés dans le **Parts No.** ne sont pas fournis.

Teile ohne **Parts No.** werden nicht geliefert.

CD MECHANISM ASSY (X92-4850-00)

Ref. No.	A d d	N e w	Parts No.	Description	Desti- nation	Ref. No.	A d d	N e w	Parts No.	Description	Desti- nation
12	3A		D10-4583-03	ARM							
13	3A		D10-4584-03	ARM							
14	3B		D10-4585-03	ARM							
15	2A		D10-4586-13	SLIDER							
16	3B		D10-4587-32	SLIDER							
17	2B		D10-4588-13	SLIDER							
18	2B		D10-4595-04	ARM							
19	3B		D10-4596-14	ARM							
22	2A		D13-2151-04	GEAR							
23	2B		D13-2152-04	GEAR							
24	3B		D13-2153-04	GEAR							
25	3B		D13-2154-04	GEAR							
26	3B		D13-2155-04	WORM							
27	2B		D13-2156-14	GEAR							
28	3B		D13-2157-04	GEAR							
29	3B		D13-2158-04	GEAR							
30	2B		D13-2168-04	GEAR							
31	3B		D13-2171-04	GEAR							
32	2B		D13-2172-03	RACK (GEAR)							
33	2A		D14-0759-04	ROLLER							
35	2B		D21-2382-04	SHAFT							
36	1A		D23-0954-04	RETAINER							
37	1B		D39-0246-05	DAMPER							
38	2B		G01-3072-04	EXTENSION SPRING							
39	2A		G01-3073-04	TORSION COIL SPRING							
40	2A		G01-3074-04	EXTENSION SPRING							
41	1B		G01-3075-14	EXTENSION SPRING							
42	2A		G01-3076-04	EXTENSION SPRING							
43	1B		G01-3077-14	EXTENSION SPRING							
44	2B		G02-1399-04	FLAT SPRING							
45	2B		G02-1408-04	FLAT SPRING							
51	1A		J21-9676-22	MOUNTING HARDWARE							
52	3B		J21-9677-22	MOUNTING HARDWARE							
53	1B		J21-9678-13	MOUNTING HARDWARE							
55	1A		J90-1001-11	GUIDE							
56	1B		J90-1023-03	GUIDE							
A	2B		N09-4460-05	TAPTITE SCREW (OVAL P TAPTIT)							
B	1B		N09-4472-15	MACHINE SCREW (M1.7X8.0)							
C	2B		N09-6004-05	MACHINE SCREW (M1.7X2.5 IB-L)							
E	2B		N09-6007-05	MACHINE SCREW (PAN M2X2)							
F	1A		N09-6051-05	TAPTITE SCREW (BIND P 2X5)							
G	2A		N19-2163-04	FLAT WASHER							
H	1B		N39-2020-46	PAN HEAD MACHIN SCREW							
J	1B		N09-6108-05	MACHINE SCREW (M2*3.5TYPE3)							
K	3B		N09-6155-05	SEMS (TAPTITE SCREW) (PT2X6)							
DM1	3B		T42-1066-04	DC MOTOR ASSY (SP)							
DM2	2B		T42-1067-04	DC MOTOR ASSY (LO)							
DPU1	2B		X93-2010-00	OPTICAL PICKUP ASSY							

SPECIFICATIONS

KDC-MP425/MP6026

● FM

Frequency Range (Frequency step)

KDC-MP425	87.9MHz~107.9MHz (200kHz)
KDC-MP6026	87.5MHz~108.0MHz (50kHz) 87.9MHz~107.9MHz (200kHz)

Channel Space Selection	50k/200kHz
Usable Sensitivity (S/N 30dB)	9.3dBf (0.8 μ V/75 Ω)
Quieting Sensitivity (S/N 50dB)	15.2dBf (1.6 μ V/75 Ω)
Frequency Response (\pm 3.0dB)	30Hz~15kHz
S/N	70dB (MONO)
Selectivity (DIN)	\geq 80dB (\pm 400kHz)
Stereo Separation	40dB (1kHz)

● AM

Frequency Range (Frequency step)

KDC-MP425	530kHz~1700kHz (10kHz)
KDC-MP6026	531kHz~1611kHz (9kHz) 530kHz~1700kHz (10kHz)

Channel Space Selection	9k/10kHz
Usable Sensitivity (S/N 20dB)	28dB μ (25 μ V)

● CD

Laser Diode	GaAlAs (λ =780nm)
Digital Filter (D/A)	8 Times OverSampling
D/A Converter	1 Bit
Spindle Speed	1000~400 (CLV · 2 times)
Wow & Flutter	Below Mesurable Limit
Frequency Response	10Hz~20kHz (\pm 1dB)
Total Harmonic Distortion	0.01% (1kHz)
S/N Ratio	105dB (1kHz)
Dynamic Range	93dB
Channel Separation	96dB

MP3 Decode

KDC-MP425	Compliant with MPEG-1/2 Audio Layer-3
KDC-MP6026	Compliant with MPEG-1.0/2.0/2.5 Audio Layer-3

WMA Decode

KDC-MP425	Compliant with WINDOWS MEDIA AUDIO
KDC-MP6026	Compliant with WINDOWS MEDIA AUDIO 8

● Preout Level/Load-Unbalanced 2000mV/10k Ω (CD/CD-CH)

● Preout Impedance \leq 600 Ω

● AMP

Maximum Power 50W x 4

Full Bandwidth Power (at less than 1% THD) 22W x 4

● TONE

Bass 100Hz \pm 10dB

Middle 1kHz \pm 10dB

Treble 10kHz \pm 10dB

● GENERAL

Operating voltage (11~16V allowable) 14.4V

Current Consumption 10A

Installation Size (W x H x D) 182 x 53 x 155 mm
7-3/16 x 2-1/16 x 6-1/10 in

Weight 1.20kg (2.64lbs)

KDC-W6027/W6027Y

● FM

Frequency Range (Frequency step) 87.5MHz~108.0MHz (50kHz)

Usable Sensitivity (S/N 26dB) 0.7 μ V/75 Ω

Quieting Sensitivity (S/N 46dB) 1.6 μ V/75 Ω

Frequency Response (\pm 3.0dB) 30Hz~15kHz

S/N 65dB (MONO)

Selectivity (DIN) \geq 80dB (\pm 400kHz)

Stereo Separation 35dB (1kHz)

● MW (AM)

Frequency Range (Frequency step) 531kHz~1611kHz (9kHz)

Usable Sensitivity (S/N 20dB) 25 μ V

● LW

Frequency range 153kHz~281kHz

Usable Sensitivity (S/N 20dB) 45 μ V

● CD

Laser Diode GaAlAs (λ =780nm)

Digital Filter (D/A) 8 Times OverSampling

D/A Converter 1 Bit

Spindle Speed 1000~400 (CLV · 2 times)

Wow & Flutter Below Mesurable Limit

Frequency Response 10Hz~20kHz (\pm 1dB)

Total Harmonic Distortion 0.01% (1kHz)

S/N Ratio 105dB (1kHz)

Dynamic Range 93dB

Channel Separation 96dB

MP3 Decode Compliant with MPEG-1.0/2.0/2.5 Audio Layer-3

WMA Decode Compliant with WINDOWS MEDIA AUDIO 8

● Preout Level/Load-Unbalanced 2000mV/10k Ω (CD/CD-CH)

● Preout Impedance \leq 600 Ω

● AMP

Maximum Power 50W x 4

PWR DIN45324, +B=14.4V 28W x 4

● TONE

Bass 100Hz \pm 10dB

Middle 1kHz \pm 10dB

Treble 10kHz \pm 10dB

● GENERAL

Operating voltage (11~16V allowable) 14.4V

Current Consumption 10A

Installation Size (W x H x D) 182 x 53 x 155 mm

Weight 1.20kg (2.64lbs)

KENWOOD follows a policy of continuous advancements in development. For this reason specifications may be changed without notice.

KENWOOD CORPORATION

2967-3, Ishikawa-machi, Hachioji-shi, Tokyo, 192-8525 Japan

KENWOOD USA CORPORATION

P.O. Box 22745, 2201 East Dominguez Street, Long Beach, CA 90801-5745, U.S.A.

KENWOOD ELECTRONICS CANADA INC.

6070 Kestrel Road, Mississauga, Ontario, Canada L5T 1S8

KENWOOD ELECTRONICS LATIN AMERICA S.A.

P.O. Box 55-2791 Paillilla, Plaza Credicorp Bank Panama, Piso 9, Oficina 901, Calle 50, Panama, Rep. de Panama

KENWOOD ELECTRONICS BRASIL LTDA.

Alameda Ministro Rocha Azevedo No. 456, Edifício Jaú, 10o Andar, Cerqueira César, Cep 0140-001, São Paulo-SP-Brasil

KENWOOD ELECTRONICS UK LIMITED

Kenwood House, Dwight Road, Watford, Herts, WD18 9EB, United Kingdom

KENWOOD ELECTRONICS DEUTSCHLAND GMBH

Rembrücker-Str. 15, 63150 Heusenstamm, Germany

KENWOOD ELECTRONICS FRANCE S.A.

13, Boulevard Ney, 75018 Paris, France

KENWOOD ELECTRONICS BELGIUM N.V.

Leuvensesteenweg 248 J, 1800 Vilvoorde, Belgium

KENWOOD ELECTRONICS ITALIA S.p.A.

Via G. Sirtori 7/9, 20129 Milano, Italy

KENWOOD IBÉRICA S.A.

Bolivia, 239-08020 Barcelona, Spain

KENWOOD ELECTRONICS AUSTRALIA PTY. LTD. (A.C.N. 001 499 074)

16 Giffnock Avenue, Centrecourt Estate, North Ryde, N.S.W. 2113, Australia

KENWOOD ELECTRONICS (HONG KONG) LTD.

Unit 3712-3724, Level 37, Tower 1, Metroplaza, 223 Hing Fong Road, Kwai Fong, N.T., Hong Kong

KENWOOD ELECTRONICS GULF FZE

P.O. Box 61318, Jebel Ali, Dubai, U.A.E.

KENWOOD ELECTRONICS (THAILAND) CO., LTD.

2019 New Pechburi Road, Bangkok, Huaykwang, Bangkok, 10320 Thailand

KENWOOD ELECTRONICS SINGAPORE PTE. LTD.

1 Genting Lane, #07-00, Kenwood Building, Singapore, 349544

KENWOOD ELECTRONICS (MALAYSIA) SDN BHD

#4.01 Level 4, Wisma Academy Lot 4A, Jalan 19/1, 46300 Petaling Jaya, Selangor Darul Ehsan, Malaysia